

Test report no.: <i>Prüfbericht-Nr.:</i>	CN23GON0 001	Order No.: <i>Auftragsnr.:</i>	168436467	Page 1 of 32 <i>Seite 1 von 32</i>
Client reference no.: <i>Kunden-Referenz-Nr.:</i>	N/A	Order date: <i>Auftragsdatum:</i>	2023.07.24	
Client: <i>Auftraggeber:</i>	DNK POWER COMPANY LIMITED Floor 7, 35 Building, Tongfuyu Industry Park, Hua Fan Road, Da Lang Street, LongHua District, Shenzhen City, Guangdong, P.R. China			
Test item: <i>Prüfgegenstand:</i>	Li-ion Polymer Battery			
Identification / Type no.: <i>Bezeichnung / Typ-Nr.:</i>	DNK 701535			
Order content: <i>Auftrags-Inhalt:</i>	TÜVus mark approval			
Test specification: <i>Prüfgrundlage:</i>	UL 2054:2021 R3.22			
Date of sample receipt: <i>Wareneingangsdatum:</i>	2023.07.28			
Test sample no.: <i>Prüfmuster-Nr.:</i>	2307170576A-001~022			
Testing period: <i>Prüfzeitraum:</i>	2023.07.31 to 2023.10.23			
Place of testing: <i>Ort der Prüfung:</i>	Shenzhen LCS Compliance Testing Laboratory Ltd.			
Testing laboratory: <i>Prüflaboratorium:</i>	TÜV Rheinland (Shenzhen) Co., Ltd.			
Test result*: <i>Prüfresultat*:</i>	Pass			
created by: <i>erstellt von:</i>	<i>Jeffrey Qin</i>			
Date: 2023.10.24 <i>Datum:</i>	Jeffrey Qin	Issue date: 2023.10.24 <i>Ausstellungsdatum:</i>	Kaman Qiu	
Position / Stellung:	Project Engineer	Position / Stellung:	Reviewer	
Other: <i>Sonstiges:</i>	1. The complete test report includes the following attachments: - Attachment 1: Equipment list (1 page); - Attachment 2: Photo documents (4 pages).			
Condition of the test item at delivery: <i>Zustand des Prüfgegenstandes bei Anlieferung:</i>	Test item complete and undamaged Prüfmuster vollständig und unbeschädigt			
* Legend: P(ass) = passed a.m. test specification(s) F(ail) = failed a.m. test specification(s) N/A = not applicable N/T = not tested * Legende: P(ass) = entspricht o.g. Prüfgrundlage(n) F(ail) = entspricht nicht o.g. Prüfgrundlage(n) N/A = nicht anwendbar N/T = nicht getestet				
This test report only relates to the above mentioned test sample. Without permission of the test center this test report is not permitted to be duplicated in extracts. This test report does not entitle to carry any test mark. <i>Dieser Prüfbericht bezieht sich nur auf das o.g. Prüfmuster und darf ohne Genehmigung der Prüfstelle nicht auszugsweise vervielfältigt werden. Dieser Bericht berechtigt nicht zur Verwendung eines Prüfzeichens.</i>				

Test report no.: CN23GON0 001
 Prüfbericht-Nr.

Page 2 of 32
 Seite 2 von 32

Remarks
 Anmerkungen

1	<p>The equipment used during the specified testing period was calibrated according to our test laboratory calibration program. The equipment fulfils the requirements included in the relevant standards. The traceability of the test equipment used is ensured by compliance with the regulations of our management system. Detailed information regarding test conditions, equipment and measurement uncertainty is available in the test laboratory and could be provided on request.</p> <p><i>Alle eingesetzten Prüfmittel waren zum angegebenen Prüfzeitraum gemäß eines festgelegten Kalibrierungsprogramms unseres Prüfhauses kalibriert. Sie entsprechen den in den Prüfprogrammen hinterlegten Anforderungen. Die Rückverfolgbarkeit der eingesetzten Prüfmittel ist durch die Einhaltung der Regelungen unseres Managementsystems gegeben. Detaillierte Informationen bezüglich Prüfkonditionen, Prüfequipment und Messunsicherheiten sind im Prüflabor vorhanden und können auf Wunsch bereitgestellt werden.</i></p>
2	<p>As contractually agreed, this document has been signed digitally only. TÜV Rheinland has not verified and unable to verify which legal or other pertaining requirements are applicable for this document. Such verification is within the responsibility of the user of this document. Upon request by its client, TÜV Rheinland can confirm the validity of the digital signature by a separate document. Such request shall be addressed to our Sales department. An environmental fee for such additional service will be charged.</p> <p><i>Wie vertraglich vereinbart, wurde dieses Dokument nur digital unterzeichnet. Der TÜV Rheinland hat nicht überprüft, welche rechtlichen oder sonstigen diesbezüglichen Anforderungen für dieses Dokument gelten. Diese Überprüfung liegt in der Verantwortung des Benutzers dieses Dokuments. Auf Verlangen des Kunden kann der TÜV Rheinland die Gültigkeit der digitalen Signatur durch ein gesondertes Dokument bestätigen. Diese Anfrage ist an unseren Vertrieb zu richten. Eine Umweltgebühr für einen solchen zusätzlichen Service wird erhoben.</i></p>
3	<p>Test clauses with remark of * are subcontracted to qualified subcontractors and described under the respective test clause in the report. Deviations of testing specification(s) or customer requirements are listed in specific test clause in the report.</p> <p><i>Prüfklausel mit der Note * wurden an qualifizierte Unterauftragnehmer vergeben und sind unter der jeweiligen Prüfklausel des Berichts beschrieben. Abweichungen von Prüfspezifikation(en) oder Kundenanforderungen sind in der jeweiligen Prüfklausel im Bericht aufgeführt.</i></p>
4	<p>The decision rule for statements of conformity, based on numerical measurement results, in this test report is based on the "Zero Guard Band Rule" and "Simple Acceptance" in accordance with ILAC G8:2019 and IEC Guide 115:2021, unless otherwise specified in the applied standard mentioned on Page 1 of this report or requested by the customer. This means that measurement uncertainty is not taken in account and hence also not declared in the test report. For additional information to the resulting risk based of this decision rule please refer to ILAC G8:2019.</p> <p><i>Die Entscheidungsregel für Konformitätserklärungen basierend auf numerischen Messergebnissen in diesem Prüfbericht basiert auf der "Null-Grenzwert-Regel" und der "Einfachen Akzeptanz" gemäß ILAC G8:2019 und IEC Guide 115:2021, es sei denn, in der auf Seite 1 dieses Berichts genannten angewandten Norm ist etwas anderes festgelegt oder vom Kunden gewünscht. Dies bedeutet, dass die Messunsicherheit nicht berücksichtigt wird und daher auch nicht im Prüfbericht angegeben wird. Zu weiteren Informationen bezüglich des Risikos durch diese Entscheidungsregel siehe ILAC G8:2019.</i></p>

Test item particulars:

Information about the product needed to establish a correct test program, such as product mobility, type of power connections and similar. (Test item particulars are selected by the TRF Originator base on the requirements in the standard)

Designation.....	: DNK 701535
Trademark.....	: N/A
Nominal voltage.....	: 3.7V
Rated capacity	: 350mAh
Maximum charge voltage.....	: 4.25V
Maximum charge current.....	: 175mA
Final voltage	: 3.0V
Ambient temperature range.....	: 10~45°C (charge), -20~60°C (discharge)
Recommend charging method declared by the manufacturer.....	: 70mA constant current charge to 4.25V, then constant voltage 4.25V charge until charging current declines to 3.5mA.

Testing:
Test clauses and results:

cl.11 Short-Circuit Test	: P
cl.12 Abnormal Charging Test.....	: P
cl.13 Abusive Overcharge Test	: P
cl.14 Forced-Discharge Test.....	: N/A
cl.15 Limited Power Source Test.....	: N/A
cl.16 Battery Pack Component Temperature Test.....	: P
cl.17 Battery Pack Surface Temperature Test.....	: N/A
cl.18 Crush Test	: N/A
cl.19 Impact Test	: N/A
cl.20 Shock Test.....	: N/A
cl.21 Vibration Test	: N/A
cl.23 Steady Force Test	: N/A
cl.24 Mold Stress Relief Test	: N/A
cl.25 Drop Impact Test.....	: N/A
cl.29 Label Performance Test	: N/A

Testing location:

Shenzhen LCS Compliance Testing Laboratory Ltd.
 Room 101, 201, Building A and Room 301, Building C, Juji Industrial Park, Yabianxueziwei, Shajing Street, Bao'an District, Shenzhen, Guangdong, China

General remarks:

This report shall not be reproduced, except in full, without the written approval of the testing laboratory. The test results presented in this report relate only to the object tested.
 "(see remark #)" refers to a remark appended to the report.
 "(see appended table)" refers to a table appended to the report.
 Throughout this report a point is used as the decimal separator.

Copy of marking plate:

Red wire (+)	Black wire (-)	
Li-ion Polymer Battery		
Model: DNK 701535		
3.7V, 350mAh, 1.295Wh		
Date: YYYYMMDD		
DNK POWER COMPANY LIMITED		

Label

Information for safety mentioned on batteries package.

CAUTION:

Risk of Fire and Burns. Do Not Open, Crush, Heat Above (manufacturer's specified maximum temperature charge 45°C, discharge 60°C) or Incinerate.

Follow Manufacturer's Instructions.

Remark:

For the date code "YYYYMMDD":

"YYYY" means year for manufacture;

"MM" means month for manufacture;

"DD" means day for manufacture.

Description of the product:

This Li-ion Polymer Battery is constructed with one cell (1S1P) and over-current and short-circuits protection circuit.

The component cell (model: DNK 701535) is approved by TÜV Rheinland according to UL 1642, Cert No.: US 72302558 01, which passed all single cell tests.

- 1) The battery has not been evaluated in combination with charger(s) or host product(s). Additional evaluation to determine compliance may be required on the combination(s) in the end product evaluation.
- 2) The battery was evaluated for a maximum charger current and maximum voltage limit outlined in the Table below. The end product evaluation shall ensure that current and voltage limits noted are maintained.

The Li-ion Polymer Battery mainly composed of:

- Protective circuit module
- Li-ion cell (1S1P)
- DC connector
- Wiring

The EUT was evaluated for a maximum charge current and maximum voltage limit outlined in the table below.

Model	Rated capacity	Nominal voltage	Nominal Charge Current	Nominal Discharge Current	Max. Charge Current	Max. Discharge Current	Max. Charge Voltage	Specified final voltage
DNK 701535	350mAh	3.7V	70mA	70mA	175mA	175mA	4.25V	3.0V

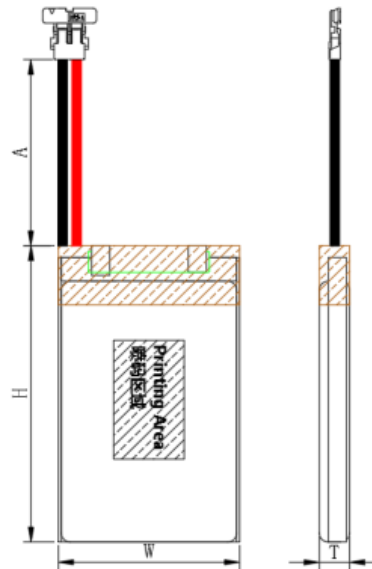
Construction:

Item	Description	Dimension
T	Battery pack Thickness max.	7mm
W	Battery pack Width max.	15mm
H	Battery pack Height max.	37mm

Battery

Circuit diagram:

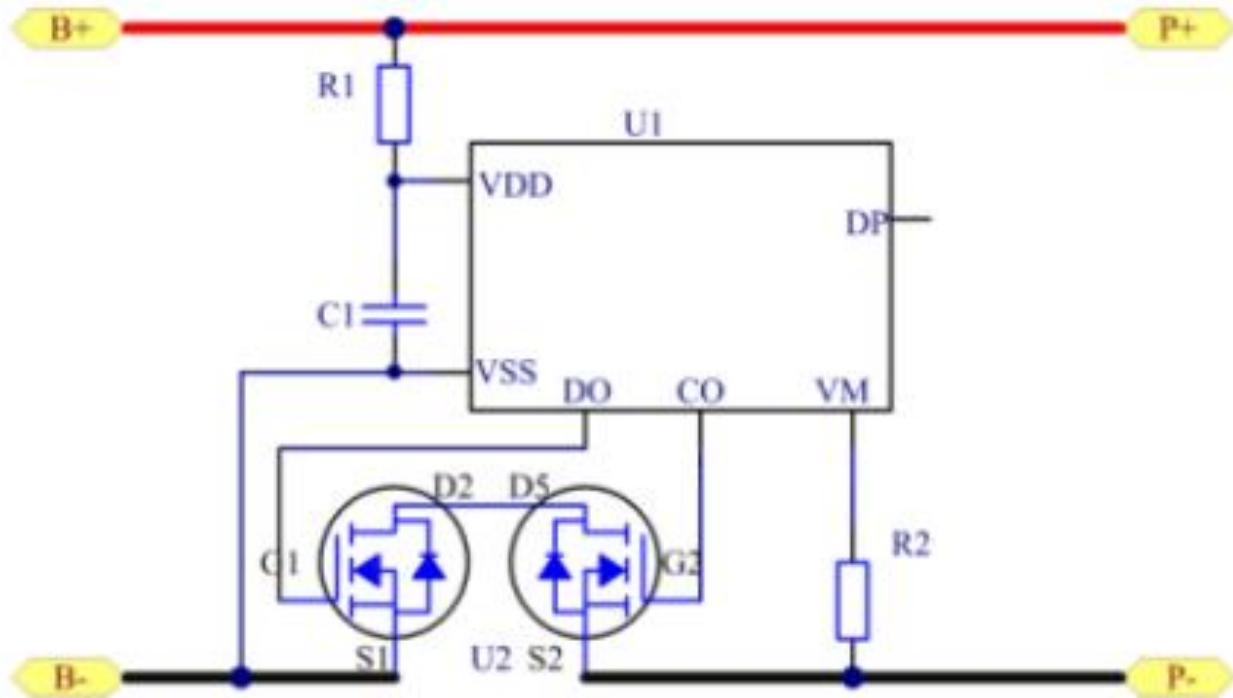

Factory:

Guangdong YFX New Energy Co.,Ltd

Building 41, Zhongnan HighTech Xinhui Rongzhi Chuangmei Industrial Valley, No.44, Xinhang Road, Siqian Town, Xinhui District, Jiangmen, Guangdong, P.R. China.

UL 2054:2021			
Clause	Requirement + Test	Result - Remark	Verdict
INTRODUCTION			
1	Scope		P
1.1	These requirements cover portable primary (nonrechargeable) and secondary (rechargeable) batteries for use as power sources in products. These batteries consist of either a single electrochemical cell or two or more cells connected in series, parallel, or both, that convert chemical energy into electrical energy by chemical reaction.		P
1.2	These requirements are intended to reduce the risk of fire or explosion when batteries are used in a product. The proper use of these batteries in a particular application is dependent on their use in a complete product that complies with the requirements applicable to such a product.		P
1.3	These requirements are intended to cover batteries for general use and do not include the combination of the battery and the host product which are covered by requirements in the host product standard.		P
1.4	These requirements are also intended to reduce the risk of injury to persons due to fire or explosion when batteries are removed from a product to be transported, stored, or discarded.		P
1.5	These requirements do not cover the toxicity risk that results from the ingestion of a battery or its contents, nor the risk of injury to persons that occurs if a battery is cut open to provide access to its contents.		P
2	Units of Measurement		P
2.1	Values stated without parentheses are the requirement. Values in parentheses are explanatory or approximate information.		P
3	Components		P
3.1	A component of a product covered by this Standard shall: a) Comply with the requirements for that component as specified in this Standard; b) Be used in accordance with its rating(s) established for the intended conditions of use; and c) Be used within its established use limitations or conditions of acceptability.		P
3.2	A component of a product covered by this Standard is not required to comply with a specific component requirement that: a) Involves a feature or characteristic not required in the application of the component in the product; b) Is superseded by a requirement in this standard; or c) Is separately investigated when forming part of another component, provided the component is used within its established ratings and limitations.		P
3.3	A component shall be used in accordance with its rating established for the intended conditions of use.		P
3.4	Specific components are incomplete in construction features or restricted in performance capabilities. Such components are intended for use only under limited conditions, such as certain temperatures not exceeding specified limits, and shall be used only under those specific conditions.		P
3.5	A component that is also intended to perform other functions such as overcurrent protection, ground-fault circuit-interruption, surge suppression, any other similar functions, or any combination thereof, shall comply additionally with the requirements of the applicable UL Standard(s) that cover devices that provide those functions.		P
4	Referenced Publications		P

UL 2054:2021			
Clause	Requirement + Test	Result - Remark	Verdict
4.1	Any undated reference to a code or standard appearing in the requirements of this Standard shall be interpreted as referring to the latest edition of that code or standard.		P
4.2	The following publications are referenced in this Standard: UL 248-14, Low-Voltage Fuses – Part 14, Supplemental Fuses UL 746C, Polymeric Materials – Use in Electrical Equipment Evaluations UL 796, Printed-Wiring Boards UL 969, Marking and Labeling Systems UL 1434, Thermistor-Type Devices UL 1642, Lithium Batteries UL 60691, Thermal-Links – Requirements and Application Guide UL 60730-1, Automatic Electrical Controls – Part 1: General Requirements		P
5	Glossary		P
CONSTRUCTION			
6	General		P
6.1	Casing and enclosure		P
6.1.1	The casing of a cell or single cell battery, or the enclosure of a battery pack shall have the strength and rigidity required to resist the possible abuses, that it is exposed to during its intended use, in order to reduce the risk of fire or injury to persons.	The casing of a cell complied with the requirements.	P
6.1.2	The casing of a cell, or single cell battery, or the enclosure of a battery pack shall be rigid enough to prevent flexing that would result in damage to the cells or internal protective components. A tool providing the mechanical advantage of a pliers, hacksaw, or similar tool, shall be the minimum mechanical capability required to open the cell casing or battery pack enclosure.		P
	Exception No. 1: This requirement does not apply to a cell or a single cell battery containing electrodes with less than 0.04 g (0.0014 oz) of active mass. This requirements does not apply to a lithium ion polymer or lithium polymer cell (i.e. pouch type cells) of a battery pack, which rely upon the battery pack enclosure or end use application for mechanical protection.		N/A
	Exception No. 2: This requirement does not apply to incomplete battery packs that rely upon the end use application for mechanical protection.	Mechanical protection will be provided in end product.	P
	Exception No. 3: Single cell battery packs employing cells with rigid casings that comply with all of the cell tests of UL 1642 or Table 8.1 as applicable, may rely on the cell casing as part of the rigid enclosure requirement provided that internal connections and pack circuitry are provided with a suitable protection against damage as determined by the applicable battery enclosure tests in Sections 23 – 25.		N/A

UL 2054:2021			
Clause	Requirement + Test	Result - Remark	Verdict
6.1.3	For battery packs with plastic outer enclosures, the outer enclosure of the battery shall be designed such that it is not capable of being opened using simple tools, such as a screwdriver. The enclosure shall be ultrasonically welded, or secured by equivalent means. Adhesives complying with the adhesive requirements of UL 746C, single use or tamper-proof screws are considered equivalent means.	No plastic outer enclosure.	N/A
6.1.4	The outer enclosure material of the battery pack shall be classed as V-1 or less flammable in the minimum part thickness in accordance with UL 746C.		N/A
	Exception: Materials are not required to be classed as V-1 or less flammable when they comply with the Enclosure Flammability – 20 mm (3/4 inch) Flame test described in UL 746C.		N/A
6.1.5	Openings in battery pack enclosures shall be minimized to prevent damage to cells, connections, and internal circuitry and shorting of electrical spacings within the pack. Enclosure openings shall not be located over cells that do not comply with the rigid casing requirements of 6.1.2 or over protective circuitry and connections where damage or shorting from debris entering the enclosure could result in a hazard.	No opening exists.	N/A
6.2	Electrolyte		P
6.2.1	A cell shall not contain pressurized vapor or liquid that expels materials forcibly when the battery casing is punctured with a grinding wheel under laboratory conditions at a temperature of 23 ± 2 °C (73 ± 3.6 °F).	The component cell is approved according to UL 1642.	P
6.3	Wiring and terminals		P
6.3.1	Wiring shall be insulated and acceptable for the purpose, when considered with respect to temperature, current, and voltage to which the wiring is likely to be subjected within the battery pack.	Complied.	P
6.3.2	The wiring splice or connection shall be mechanically secured and shall provide electrical contact without strain on connections and terminals. Wiring shall be secured and routed away from sharp edges or other parts that may compromise wiring insulation.	Complied.	P
6.4	External battery pack connectors		P
6.4.1	An external battery pack connector shall be constructed to prevent inadvertent short circuiting of its terminals unless the pack meets the limited power source requirements of the Limited Power Source Test, Section 15. Examples of methods to prevent inadvertent short-circuiting include recessing the terminals, providing circuitry that prevents inadvertent short circuiting, providing covers over the terminals, use of keyed connectors, and the like.	Complied.	P

UL 2054:2021			
Clause	Requirement + Test	Result - Remark	Verdict
6.4.2	Insulating material for external battery pack connectors, outside the enclosure, shall have a V-2 minimum flame rating unless the pack meets the limited power source requirements of the Limited Power Source Test, Section 15. External connectors forming part of the fire enclosure shall be V-1 minimum.	V-0 class, See Critical Component Table.	P
6.5	Printed wiring boards		P
6.5.1	Printed wiring boards mounting battery circuit components shall be rated V-1 minimum and comply with UL 796.	V-0 class, See Critical Component Table.	P
6.6	Lithium Ion Systems Only		P
6.6.1	The voltage of each cell or each cellblock consisting of parallel-connected plural cells should not exceed the upper limit of the charging voltage specified by the cell manufacturer.	Max. charging voltage of each component cell: 4.25V, not exceed 4.25V specified by the cell manufacturer.	P
6.6.2	For the battery consisting of a single cell or a single cellblock, it should be confirmed that the charging voltage of the cell does not exceed the upper limit of the charging voltage specified by the cell manufacturer.		P
6.6.3	For the battery consisting of series-connected plural single cells or series-connected plural cellblocks, it should be confirmed that the voltages of any one of the single cells or single cellblocks does not exceed the upper limit of the charging voltage, specified by the cell manufacturer, by monitoring the voltage of every single cell or the single cellblocks.		N/A
6.6.4	Compliance for 6.6.1 – 6.6.3 can be achieved through analysis of the battery protection circuit or if unable to determine through analysis, than through monitoring values during the test of Section 16.	Complied, by protection circuit analysis.	P
PERFORMANCE			
7	General		P
7.1	Batteries are to be tested as described in Sections 11 – 28 and as follows: a) Section 14, Forced-Discharge Test, is applicable only to cells intended to be used in multicell series applications, such as battery packs; b) Section 15, Limited Power Source Test, is an optional requirement only carried out upon manufacturer's request; and c) The Battery Enclosure Tests, Sections 22 – 25 (including the Steady Force, Mold Stress Relief, and Drop Impact Tests) are intended only for batteries that have an outer enclosure.	Tested as required.	P

UL 2054:2021			
Clause	Requirement + Test	Result - Remark	Verdict
7.2	With the exception of the Projectile Test of Section 26, cells and/or batteries shall not explode or catch fire as a result of the tests in this standard. For the Shock Test, Section 20, Vibration Test, Section 21, Steady Force Test, Section 23, Mold Stress Relief Test, Section 24, Drop Impact Test, Section 25, and the Temperature Cycling Test, Section 28 the samples shall also not vent or leak. For these tests unacceptable leakage is deemed to have occurred when the resulting mass loss exceeds the values shown in Table 7.1, Venting and Leakage Mass Loss Criteria.		N/A
7.3	Certain end product devices require that the power output of a battery be limited. The Limited Power Source Test described in Section 15 is to be used to determine whether a cell or battery is suitable in such applications where fire hazards may otherwise exist.		N/A
8	Samples		P
8.1	Unless otherwise indicated, fresh cells or batteries in the fully charged state are to be used for the tests described in Sections 11 – 28. The test program and number of samples to be used in each test is shown in Table 8.1 and Table 8.2, for cell testing and battery pack testing, respectively.	Tested as required.	P
	Exception: In lieu of the requirements outlined in Table 8.1, cells constructed of lithium metal, lithium alloy or lithium ion, that are used in batteries, shall meet the requirements in UL 1642.	The component cell is approved according to UL 1642.	P
8.2	When a battery pack is tested in accordance with Table 8.2, the cells comprising that battery pack shall also be tested in accordance with Table 8.1 if they have not already been.		N/A
	Exception: In lieu of the requirements outlined in Table 8.1, cells constructed of lithium metal, lithium alloy or lithium ion, that are used in batteries, shall meet the requirements in UL 1642.	The component cell is approved according to UL 1642.	P
8.3	All batteries shall be fully charged in accordance with the manufacturer's specifications prior to testing except for the samples to be subjected to the Abnormal Charging and Abusive Overcharge Tests, which shall be discharged to the manufacturer specified end point voltage using the manufacturer specified current prior to testing.	Suitable samples prepared according to each test clause requirement.	P
9	Important test considerations		P
9.1	As some batteries explode in the tests described in Sections 11 – 28, it is important that personnel be protected from the flying fragments, explosive force, sudden release of heat, chemical burns, and noise results from such explosions. The test area is to be well ventilated to protect personnel from possible harmful fumes or gases.	Test facilities checked and complied.	P

UL 2054:2021			
Clause	Requirement + Test	Result - Remark	Verdict
9.2	The temperatures on the surface of the battery casings shall be monitored during the tests described in Sections 11, 12, 13, 18, and 19. All personnel involved in the testing of batteries are to be instructed never to approach a battery until the surface temperature returns to ambient temperature..	Temperature was recorded on the center of the cell casing for so requested clauses, also see appended tables.	P
9.3	The tests described in Section 26, Projectile Test, shall be conducted in a separate room or room equipped with an adequate safety barrier separating the test area from the observer.		N/A
10	Temperature measurements		P
10.1	Temperatures are to be measured by thermocouples consisting of wires not larger than 24 AWG (0.21 mm ²) and not smaller than 30 AWG (0.05 mm ²) and a potentiometer-type instrument.	Suitable thermocouples used during the test.	P
10.2	The temperature measurements on the batteries are to be made with the measuring junction of the thermocouple held tightly against the outer casing of the battery.	Fulfilled.	P
ELECTRICAL TESTS			
11	Short-Circuit Test		P
11.1	Cells shall comply with 11.1 – 11.6.	The component cell is approved according to UL 1642.	N/A
11.2	Each fully charged test sample cell, in turn, is to be short-circuited by connecting the positive and negative terminals of the battery with a circuit load having a resistance load of 80 ±20 mΩ. The temperature of the battery case is to be recorded during the test. The battery is to discharge until a fire or explosion is obtained, or until it has reached a discharged state of less than 0.2 V and/or the case temperature has returned to ±10 °C (±18 °F) of ambient temperature.		N/A
11.3	Tests are to be conducted at 20 ±5 °C (68 ±9 °F), and at 55 ±2 °C (131 ±4 °F). The cells are to reach equilibrium at 20 ±5 °C (68 ±9 °F) or 55 ±2 °C (131 ±4 °F) as applicable, before the terminals are connected.		N/A
11.4	A cell is to be tested individually unless the cell manufacturer indicates that it is intended for use in series or parallel. For series or parallel use, additional tests on five sets of batteries are to be conducted using the maximum number of cells to be covered for each configuration as specified by the manufacturer.		N/A
11.5	A cell is to be tested without the assistance of protective devices unless such protective devices are integral to the cell construction. When a protective device actuates during the test, the test shall be repeated with the cell connected to the maximum load that does not cause the protective device to open.		N/A
11.6	The samples shall not explode or catch fire. The temperature of the exterior cell or battery casing shall not exceed 150°C (302°F) for lithium chemistries.		N/A

UL 2054:2021			
Clause	Requirement + Test	Result - Remark	Verdict
11.7	Battery packs shall comply with 11.8 – 11.12.		P
	Exception: Battery packs consisting of a single cell, in which the cell has already been subjected to the tests in 11.1 – 11.6 need not be subjected to the tests in 11.8 – 11.12.		P
11.8	Each fully charged test sample battery pack, in turn, is to be short-circuited by connecting the positive and negative terminals of the battery with a circuit load having a resistance load of 80 ±20 mΩ. The temperature of the battery case is to be recorded during the test. The battery is to discharge until a fire or explosion is obtained, or until it is completely discharged and/or the cell case temperature has returned to ±10 °C (±18 °F) of ambient temperature.	Tested complied.	P
11.9	Tests are to be conducted at 20 ±5 °C (68 ±9 °F) and at 55 ±5 °C (131 ±4 °F). The batteries are to reach equilibrium at 20 ±5 °C (68 ±9 °F) or 55 ±5 °C (131 ±4 °F), as applicable, before the terminals are connected.	Tested complied.	P
11.10	Battery pack constructions are to be subjected to a single fault across any protective device in the load circuit of the battery under test. When protective devices actuate during the test, the test shall be repeated with the battery pack connected to the maximum load that does not cause the protective devices to open.	A single fault applied on MOSFET U2 (PinS1-PinS2). See appended table 11 for details.	P
	Exception: A positive temperature coefficient device which complies with the tests specified in UL 1434, UL 60730-1, or other protective devices determined to be reliable, may remain in the circuit without being faulted. See 5.21. Other standards that may apply are UL 248-14 and UL 60691.		N/A
11.11	One of the above five test sample battery packs, tested at 20 ±5 °C (68 ±9 °F) shall be evaluated with the following additional conditions in place. The terminals are to be subjected to a short circuit condition with a resistance that is capable of withstanding the short-circuit current and creating a short circuit condition with a total external resistance of 80 ±20 mΩ. The test is to be conducted on a tissue paper covered soft wood surface and the sample battery pack and bare conductor is to be covered with a single layer of cheesecloth.	Complied.	P
11.12	For all samples tested, the samples shall not explode or catch fire and the tests shall not result in chemical leaks caused by cracking, rupturing or bursting of the cell casing. The temperature of the internal cell casings shall not exceed 150°C (302°F) for lithium chemistries. For battery pack samples tested in accordance with 11.11, the cheesecloth and tissue paper shall not catch fire.	Complied.	P
12	Abnormal Charging Test		P

UL 2054:2021			
Clause	Requirement + Test	Result - Remark	Verdict
12.1	Primary batteries (for example: cells, single cell batteries, or battery packs) shall comply with 12.2 – 12.5.	Secondary batteries	N/A
12.2	Batteries discharged to the manufacturer's rated capacity are to be used for this test. The batteries are to be tested in an ambient temperature of $20 \pm 5^{\circ}\text{C}$ ($68 \pm 9^{\circ}\text{F}$).		N/A
12.3	Each fully discharged test sample battery is to be subjected to a charging current of three times the current I_c , specified by the manufacturer by connecting it in opposition to a dc-power supply. The test time is to be calculated using the formula: $t_c = \frac{2.5C}{3(I_c)}$, in which t_c is the charging time in hour C is the capacity of battery in ampere-hours, and I_c is the maximum charging current, in amperes, specified by the manufacturer. The minimum charging time is to be 7 hours.		N/A
	Exception: At the manufacturer's discretion, test currents greater than the specified three times rated I_c can be applied to expedite the test timeframe, with the minimum charging times as 7 h.		N/A
12.4	When a protective device that has been investigated for the purpose, actuates during the test, the test shall be repeated with the battery supply connected to the maximum load that does not cause the protective device to open. A protective device that has not been investigated for the purpose shall be short-circuited.		N/A
12.5	The samples shall not explode or catch fire. For battery pack samples, tests shall not result in chemical leaks caused by cracking, rupturing or bursting of the battery casing.		N/A
12.6	Secondary cells shall comply with 12.7 – 12.9.	Secondary battery packs	N/A
12.7	The cells are to be tested in an ambient temperature of $20 \pm 5^{\circ}\text{C}$ ($68 \pm 9^{\circ}\text{F}$). Each battery shall be discharged at a constant current of $0.2\text{ C}/1\text{ h}$, to a manufacturer specified discharge endpoint voltage.		N/A
12.8	The cells are to be charged with a constant maximum specified charger output voltage and a current limit of three times the maximum current I_c , specified by the manufacturer. Charging duration is the time required to reach the manufacturer's specified end-of-charge condition plus seven additional hours.		N/A

UL 2054:2021			
Clause	Requirement + Test	Result - Remark	Verdict
12.9	A cell is to be tested without the assistance of protective devices, unless such protective devices are either integral to the cell constructions or have been investigated for the purpose. A re-settable protective device that actuates during the test shall be allowed to reset and the test shall be resumed, cycling as often as necessary to complete the test. When a protective device operates during the test (whether re-settable or not) the test is repeated with the same charging time, but with the cell connected to the maximum load that does not cause the protective devices to operate. A protective device that is not integral to the cell and that has not been investigated for the purpose is to be short-circuited.		N/A
12.10	The samples shall not explode or catch fire.		N/A
12.11	Secondary battery packs shall comply with 12.12 – 12.14.		P
12.12	The batteries are to be tested in an ambient temperature of $20 \pm 5^{\circ}\text{C}$ ($68 \pm 9^{\circ}\text{F}$). A thermocouple is to be attached to the cells of each test sample battery. Each battery shall be discharged at a constant current of $0.2\text{C}/1$ hour, to a manufacturer specified discharge endpoint voltage.	Discharge with 0.07A to endpoint voltage 3.0V.	P
12.13	Each of the test sample batteries are to be subjected to the following overcharge conditions, in sequential order. a) The battery is to be initially charged using a constant current charging mode with a current limit of three times the maximum current I_c , specified by the manufacturer until the maximum specified charger output voltage is reached. At that point, the battery is to be charged with a constant maximum specified charger output voltage and a current limit of three times the maximum current I_c . Charging duration is the time required to reach the manufacturer's specified end-of-charge condition plus seven additional hours. The temperature on the cell casing shall be monitored. A re-settable protective device such as a PTC that actuates during the test shall be allowed to reset and the test shall be resumed, cycling as often as necessary, but no less than 10 times, to complete the test. Automatic reset devices are allowed to cycle during the test. When an overcurrent protective device operates during the test, the test is repeated with the same charging time, but with the battery connected to the maximum load that does not cause the protective devices to operate. b) The charge condition in accordance with (a) shall be conducted with each single component fault that is likely to occur in the charging circuit and which would result in overcharging of the battery.	Max. constant charge voltage is 4.25V. A single fault applied on MOSFET U2 (PinS1-PinS2). See appended table 12 for details	P
	Exception No. 1: A protective device determined to be reliable may remain in the circuit without being faulted. See Section 3 and 5.21.		N/A
	Exception No. 2: For batteries without protective devices, the overcharge condition(s) in (b) do not apply.		N/A

UL 2054:2021			
Clause	Requirement + Test	Result - Remark	Verdict
12.14	The samples shall not explode or catch fire. For battery pack samples, tests shall not result in chemical leaks caused by cracking, rupturing or bursting of the internal cell casing.	No explosion or fire, or chemical leak, no chemical leaks caused by cracking, rupturing or bursting of the cell casing	P
13	Abusive Overcharge Test		P
13.1	The batteries are to be tested in an ambient temperature of 20 ±5°C (68 ±9°F).		P
13.2	Sample batteries are to be subjected to a constant charging current at 10 times the C5 amp rate, using a supply voltage sufficient to maintain the 10 times C5 amp rate throughout the duration of the test. During the test, the temperature is to be measured on the internal cell casing of each sample. The test is to continue until the cell or battery explodes, vents, or a single operation protective device operates, and the temperature of the internal cell casing reaches steady state conditions or returns to ambient. If a PTC or other re-settable protection device operates during the test, it is to be reset a minimum of 10 times during the test. An automatic reset device is allowed to cycle during the test	Complied. See appended table 13 for details	P
13.3	During the tests, batteries supplied with protective devices shall be subjected to a single component fault using any single fault condition which is likely to occur in the charging circuit and which would result in overcharging of the battery	A single fault applied on A single fault applied on MOSFET U2 (PinS1-PinS2).	P
	Exception: Protective devices determined to be reliable, may remain in the circuit without being faulted.		N/A
13.4	The samples shall not explode or catch fire.	No explosion or fire.	P
13.5	At least one of the five samples shall be subjected to the test outlined in 13.2 and 13.3 with a constant current charge 5 times the C5 rate (for example: at the C rate) with a supply voltage sufficient to maintain that rate throughout the duration of the test.	Two of 5 samples tested with 5 times the C5 rate 0.35A.	P
14	Forced-Discharged Test	Single cell.	N/A
14.1	This test is intended for cells that are to be used in multicell applications, such as battery packs. The batteries are to be tested in an ambient temperature of 20 ±5 °C (68 ±9 °F).		N/A
14.2	For multi-cell series configurations without parallel strings a fully discharged cell is to be force-discharged by connecting it in series with fully charged cells of the same kind. The number of fully charged cells to be connected in series with the discharged cell is to equal the total number of cells in the pack less one		N/A
14.3	For multi-cell series configurations with parallel strings, a fully discharged parallel string is to be force-discharged by connecting it in series with fully charged cells of the same kind. The number of fully charged cells to be connected in series with the discharged parallel string is to equal the total number of cells in the pack less the number of cells in the discharged parallel string.		N/A

UL 2054:2021			
Clause	Requirement + Test	Result - Remark	Verdict
14.4	Each of the five battery packs shall be prepared as described in 14.2 or 14.3, as applicable.		N/A
14.5	Once the completely discharged cells (or string of cells) are connected in series with the specified number of fully charged cells, the resultant battery pack is to be short circuited.		N/A
14.6	The positive and negative terminals of the sample are to be connected with a copper wire with a resistance load of $80 \pm 20 \text{ m}\Omega$. The battery is to discharge until a fire or explosion is obtained, or until it has reached a completely discharged state and the cell case temperature has returned to $\pm 10 \text{ }^\circ\text{C}$ ($\pm 18 \text{ }^\circ\text{F}$) of ambient temperature.		N/A
14.7	During the tests, batteries supplied with protective devices shall be subjected to a single component fault using any single fault condition which is likely to occur in the discharge circuit and which would result in excessive discharge of the battery.		N/A
	Exception: A positive temperature coefficient device which complies with the applicable tests specified in UL 1434 and UL 60730-1, or other protective devices determined to be reliable, may remain in the circuit without being faulted. Other standards that may apply are UL 248-14 and UL 60691.		N/A
14.8	The samples shall not explode or catch fire.		N/A
15	Limited Power Source Test		N/A
15.1	The batteries are to be tested in an ambient temperature of $20 \pm 5 \text{ }^\circ\text{C}$ ($68 \pm 9 \text{ }^\circ\text{F}$).		N/A
15.2	A battery intended to be a limited power source shall comply with one of the following: a) The output is inherently limited in compliance with Table 15.1; b) A linear or nonlinear impedance limits the output in compliance with Table 15.1. If a positive temperature coefficient device is used, it shall: 1) Comply with UL 1434; 2) Pass the tests specified in the Manufacturing Deviation and Drift Section, the Endurance Section, and the Manufacturing Deviation and Drift Section and the Endurance Section in the Annex for Requirements for Controls Using Thermistors of UL 60730-1; or 3) Meet the requirements in UL 60730-1 for a device for Type 2.AL Action; c) A regulating network or an integrated circuit (IC) current limiter, limits the output in compliance with Table 15.1, both under normal operating conditions and after any simulated single fault in the regulating network or IC current limiter (open circuit or short circuit); or d) An overcurrent protective device is used and the output is limited in compliance with Table 15.2.		N/A

UL 2054:2021			
Clause	Requirement + Test	Result - Remark	Verdict
15.3	Where an overcurrent protective device is used, it shall be a fuse or a non-adjustable, nonautoreset, electromechanical device.		N/A
15.4	Batteries shall be fully charged when conducting the measurements for Uoc, Isc, and S according to Table 15.1 and Table 15.2.		N/A
15.5	The non-capacitive load referenced in Table 15.1 and Table 15.2 shall be adjusted to develop maximum measured values of current (Isc) and power (S) that can be obtained over the time limits noted in Table 15.1 and Table 15.2. Simulated faults in a regulating network required according to 15.2(c) above are applied under these load conditions.		N/A
15.6	Batteries that meet the limited power source requirements may be marked "Limited Power Source" "LPS" to indicate that they are considered to be a limited power source. Batteries that do not meet these requirements, regardless of terminal design, shall not be marked to indicate that they are a limited power source and are restricted to applications where a limited power source is not required.	No "Limited Power Source" "LPS" mark in the label.	N/A
16	Battery Pack Component Temperature Test		P
16.1	A battery pack with enclosure shall be subjected to a normal temperature test under both input (charging) and output (discharging) conditions. As a result of this testing, temperatures on temperature sensitive components shall not exceed the limits outlined in Table 16.1.		P
16.2	For the output loading temperature test, a fully charged battery pack shall be subjected to a constant resistive loading across the output terminals of the pack with the output load current set to just below the operating limit of the discharging protection circuit. Temperatures are monitored until thermal stabilization or until the pack is at its specified endpoint voltage, whichever comes first.	The maximum discharge current is 0.8A.	P
16.3	The input loading temperature test shall be conducted on a fully discharged battery pack, discharged at a constant current of 0.2C/1 h to a manufacturer specified discharge endpoint voltage.	Discharge with 70mA to 3.0V.	P
16.4	For the input loading temperature test, a fully discharged sample shall be subjected to a CCCV charging method with the maximum charging voltage not to exceed the manufacturer's recommended maximum charging voltage limits. During the test, the charging current shall not exceed three times the maximum charge current or the operating limit of the charging protection circuit, whichever is less, during the test. Temperatures are monitored until thermal stabilization or until the pack is at its fully charged state, whichever comes first.	CC=0.525A, CV=4.25V.	P

UL 2054:2021			
Clause	Requirement + Test	Result - Remark	Verdict
16.5	Temperatures are considered to be stabilized when three successive readings taken at intervals of 10 % of the previously elapsed duration of the test, but not less than 15 min, indicate no further increase.	Tested as required.	P
16.6	Protective devices within the pack shall not operate during the test.	Tested as required.	P
16.7	Temperatures are monitored on surfaces of components using thermocouples. Thermocouples are to consist of 30 AWG wires. Larger size wires may be used, but they shall not exceed 24 AWG and shall not be large enough to result in a heat sink condition on the part under test.	Tested as required.	P
16.8	<p>During the normal temperature test, temperature measurement T shall not exceed $(T_{max} + T_{amb} - T_{ma})$ where: T is the temperature of the given part measured under the prescribed test, T_{max} is the maximum temperature specified for compliance with the test, T_{amb} is the ambient temperature during the test, T_{ma} is the maximum ambient temperature permitted by the manufacturer's specification, or 25 °C (77 °F), whichever is greater. During the test T_{amb} should not exceed T_{ma} unless agreed by all parties involved.</p>	See appended table 16/17 for details	P
17	Battery Pack Surface Temperature Test		N/A
17.1	A battery pack with enclosure shall be subjected to a normal temperature test under both input (charging) and output (discharging) conditions. As a result of this testing, temperatures on external accessible surfaces of the pack shall not exceed the limits outlined in Table 17.1.	No enclosure exist.	N/A
17.2	For the output loading temperature test, a fully charged battery pack shall be subjected to a constant resistive loading across the output terminals of the pack with the output load current set to just below the operating limit of the discharging protection circuit. Temperatures are monitored until thermal stabilization or until the pack is at its specified endpoint voltage, whichever comes first.		N/A
17.3	The input loading temperature test shall be conducted on a fully discharged battery pack, discharged at a constant current of 0.2C/1 h to a manufacturer specified discharge endpoint voltage.		N/A

UL 2054:2021			
Clause	Requirement + Test	Result - Remark	Verdict
17.4	For the input loading temperature test, a fully discharged sample shall be subjected to a CCCV charging method with the maximum charging voltage not to exceed the manufacturer's recommended maximum charging voltage limits. During the test, the charging current shall not exceed three times the maximum charge current or the operating limit of the charging protection circuit, whichever is less, during the test. Temperatures are monitored until thermal stabilization or until the pack is at its fully charged state, whichever comes first.		N/A
17.5	Temperatures are considered to be stabilized when three successive readings taken at intervals of 10 % of the previously elapsed duration of the test, but not less than 15 min, indicate no further increase.		N/A
17.6	Protective devices within the pack shall not operate during the test.		N/A
17.7	Temperatures are monitored on the accessible surfaces of the pack enclosure using thermocouples. Thermocouples are to consist of 30 AWG wires. Larger size wires may be used, but they shall not exceed 24 AWG.		N/A
17.8	During the normal temperature test, temperature measurement T shall not exceed $(T_{max} + T_{amb} - T_{ma})$ where: T is the temperature of the given part measured under the prescribed test, T _{max} is the maximum temperature specified for compliance with the test per Table 17.1, T _{amb} is the ambient temperature during the test, T _{ma} is the maximum ambient temperature permitted by the manufacturer's specification, or 25 °C (77 °F), whichever is greater. During the test T _{amb} should not exceed T _{ma} unless agreed by all parties involved.		N/A
MECHANICAL TESTS			
18	Crush Test	The component cell is approved according to UL 1642.	N/A
18.1	The batteries are to be tested in an ambient temperature of 20 ±5°C (68 ±9°F).		N/A
18.2	A battery is to be crushed between two flat surfaces. The force for the crushing is to be applied by a hydraulic ram or similar force mechanism. The flat surfaces are to be brought in contact with the cells and the crushing is to be continued until an applied force of 13 ±1.0 kN (3000 ±224 lbf) is reached. Once the maximum force has been obtained, it is to be released.		N/A

UL 2054:2021			
Clause	Requirement + Test	Result - Remark	Verdict
18.3	A cylindrical or prismatic battery is to be crushed with its longitudinal axis parallel to the flat surfaces of the crushing apparatus. A prismatic battery is also to be rotated 90 degrees around its longitudinal axis so that both the wide and narrow sides will be subjected to the crushing force. Each sample battery is to be subjected to a crushing force in only one direction. Separate samples are to be used for each test.		N/A
18.4	A coin or button battery is to be crushed with the flat surface of the battery parallel with the flat surfaces of the crushing apparatus.		N/A
18.5	The samples shall not explode or catch fire.		N/A
19	Impact Test	The component cell is approved according to UL 1642.	N/A
19.1	The batteries are to be tested in an ambient temperature of 20 ±5°C (68 ±9°F).		N/A
19.2	A test sample battery is to be placed on a flat surface. A 15.8 ±0.1 mm (5/8 ±0.004 in) diameter bar is to be placed across the center of the sample. A 9.10 ±0.46 kg (20 ±1 lb) weight is to be dropped from a height of 610 ±25 mm (24 ±1 in) onto the sample. (See Figure 19.1.)		N/A
19.3	A cylindrical or prismatic battery is to be impacted with its longitudinal axis parallel to the flat surface and perpendicular to the longitudinal axis of a 15.8 mm (5/8 in) diameter curved surface lying across the center of the test sample. A prismatic battery is also to be rotated 90° around its longitudinal axis so that both the wide and narrow sides will be subjected to the impact. Each sample battery is to be subjected to only a single impact. Separate samples are to be used for each test.		N/A
19.4	A coin or button battery is to be impacted with the flat surface of the test sample parallel to the flat surface and the 15.8 mm (5/8 in) diameter curved surface lying across its center.		N/A
19.5	The samples shall not explode or catch fire.		N/A
20	Shock Test	The component cell is approved according to UL 1642.	N/A
20.1	The cell is to be secured to the testing machine by means of a rigid mount which supports all mounting surfaces of the cell. Each cell shall be subjected to a total of three shocks of equal magnitude. The shocks are to be applied in each of three mutually perpendicular directions unless it has only two axes of symmetry in which case only two directions shall be tested. Each shock is to be applied in a direction normal to the face of the cell. For each shock the cell is to be accelerated in such a manner that during the initial 3 ms the minimum average acceleration is 75 g (where g is the local acceleration due to gravity). The peak acceleration shall be between 125 and 175 g. Cells shall be tested at a temperature of 20 ±5 °C (68 ±9 °F).		N/A

UL 2054:2021			
Clause	Requirement + Test	Result - Remark	Verdict
20.2	The samples shall not explode or catch fire.		N/A
20.3	The sample shall be examined 6 h after testing and shall not vent or leak as described in 7.2.		N/A
21	Vibration Test	The component cell is approved according to UL 1642.	N/A
21.1	The batteries are to be tested in an ambient temperature of 20 ±5°C (68 ±9°F).		N/A
21.2	A battery is to be subjected to simple harmonic motion with an amplitude of 0.8 mm (0.03 in) [1.6 mm (0.06 in) total maximum excursion].		N/A
21.3	The frequency is to be varied at the rate of 1 Hz/min between 10 and 55 Hz and return in not less than 90 nor more than 100 min. The battery is to be tested in three mutually perpendicular directions. For a battery that has only two axes of symmetry, the battery is to be tested perpendicular to each axis.		N/A
21.4	The samples shall not explode or catch fire.		N/A
21.5	The sample shall be examined 6 h after testing and shall not vent or leak as described in 7.2.		N/A
BATTERY ENCLOSURE TESTS			
22	General		N/A
22.1	The batteries are to be tested in an ambient temperature of 20 ±5°C (68 ±9°F).	No enclosure exist.	N/A
22.2	Batteries with outer plastic enclosures shall be subjected to the tests described in Sections 23, 24, and 25. Batteries with outer enclosures made from materials other than plastic, shall be subjected to the tests described in Sections 23 and 25.		N/A
23	Steady Force Test		N/A
23.1	The batteries are to be tested in an ambient temperature of 20 ±5°C (68 ±9°F).		N/A
23.2	External enclosures of the battery pack are to be subjected to a steady force of 250 ±10 N (56 ±2 lbf) for a period of 5 s, applied in turn to the top, bottom and sides of the battery pack enclosure by means of a suitable test tool providing contact over a circular plane surface 30 mm (1.2 in) in diameter.		N/A
23.3	The samples shall not explode or catch fire. The outer battery enclosure shall not crack to the extent that the cells or any protective devices are exposed. Openings in the enclosure created as a result of application of the 250 N steady force shall meet the criteria of 6.1.5.		N/A
23.4	The sample shall be examined 6 h after testing and shall not vent or leak as described in 7.2.		N/A
24	Mold Stress Relief Test		N/A

UL 2054:2021			
Clause	Requirement + Test	Result - Remark	Verdict
24.1	Each of three samples are to be placed in a full-draft circulating-air oven maintained at a uniform temperature of 70 °C (158 °F). The samples are to remain in the oven for 7 h.		N/A
	Exception: If the maximum temperature, T, recorded on the battery pack thermoplastic enclosure parts, obtained during the normal temperature test of Section 17 exceeds 60 °C (140 °F), then the oven temperature is to be maintained at a temperature equal to T + 10 °C (50 °F).		N/A
24.2	To prevent hazards from overheating energized cells, samples shall either be fully discharged prior to conditioning or provided with "dummy" cells, which are representative of the actual cells.		N/A
24.3	After careful removal from the oven and after returning to room temperature following the conditioning described in 24.3, the samples shall show no evidence of mechanical damage that would result in damage to cells or protective circuitry. In addition, the battery enclosures shall not crack, warp, or melt to the extent that the cells or any protective devices are exposed. Openings in the enclosure created as a result of the conditioning shall meet the criteria of 6.1.5.	No evidence of mechanical damage that would result in damage to cell or protective circuitry after test.	N/A
25	Drop Impact Test		N/A
25.1	The batteries are to be tested in an ambient temperature of 20 ±5°C (68 ±9°F)		N/A
	Exception: Battery packs employing plastic enclosures that are intended for use in 0 °C (32 °F) temperatures shall be conditioned for 3 h at 0 °C (or temperature specified if lower than 0 °C) prior to conducting the drop test, which shall be conducted immediately after removing the samples from the cold conditioning.		N/A
25.2	Each of three samples is to be dropped from a height of 1 m (3.28 ft) so it strikes a concrete surface in the position that is most likely to produce the adverse results in 25.3. Each sample is to be dropped three times.		N/A
25.3	The samples shall not explode or catch fire.		N/A
25.4	The sample shall be examined 6 h after testing and shall not vent or leak as described in 7.2, and the integrity of the protective devices shall be maintained.		N/A
25.5	The outer battery enclosure shall not crack to the extent that cells or any protective devices are exposed. Openings in the enclosure created as a result of the drop impact(s) shall meet the criteria of 6.1.5.		N/A
FIRE EXPOSURE TESTS			
26	Projectile Test	The component cell is approved according to UL 1642.	N/A

UL 2054:2021			
Clause	Requirement + Test	Result - Remark	Verdict
26.1	When subjected to the test described in 26.2 – 26.5 no part of an exploding cell or battery shall create a hole in the wire screen cage or penetrate the wire screen cage such that some or all of the cell or battery protrudes through the screen cage.		N/A
26.2	Each test sample cell or battery is to be placed on a screen that covers a 102 mm (4 in) diameter hole in the center of a platform table. The screen is to be constructed of steel wire mesh having 20 openings per inch (25.4 mm) and a wire diameter of 0.43 mm (0.017 in).		N/A
26.3	The screen is to be mounted 38 mm (1-1/2 in) above a burner. The fuel and air flow rates are to be set to provide a bright blue flame that causes the supporting screen to glow a bright red.		N/A
26.4	An eight-sided covered wire cage, 610 mm (2 ft) across and 305 mm (1 ft) high, made from metal screening is to be placed over the test sample. See Figure 26.1. The metal screening is to be constructed from 0.25 mm (0.010 in) diameter aluminum wire with 16 – 18 wires per inch (25.4 mm) in each direction.		N/A
26.5	The sample is to be heated and shall remain on the screen until it explodes or the cell or battery has ignited and burned out. It is not required to secure the sample in place unless it is at risk of falling off the screen before the test is completed. When required, the sample shall be secured to the screen with a single wire tied around the sample.		N/A
ENVIRONMENTAL TESTS			
27	Heating Test	The component cell is approved according to UL 1642.	N/A
27.1	The sample shall not explode or catch fire when subjected to the test described in 27.2 – 27.4.		N/A
27.2	A battery is to be heated in a gravity convection or circulating air oven with an initial temperature of 20 ±5 °C (68 ±9 °F).		N/A
27.3	The temperature of the oven is to be raised at a rate of 5 ±2 °C (9 ±4 °F) per minute to a temperature of 130 ±2 °C (266 ±4 °F) and remain at that temperature for 10 min.		N/A
27.4	The sample shall return to room temperature (20 ±5°C) and then be examined.		N/A
28	Temperature Cycling Test	The component cell is approved according to UL 1642.	N/A

UL 2054:2021			
Clause	Requirement + Test	Result - Remark	Verdict
28.1	The batteries are to be placed in a test chamber and subjected to the following cycles: a) Raising the chamber-temperature to 70 ±3 °C (158 ±5 °F) within 30 min and maintaining this temperature for 4 h. b) Reducing the chamber temperature to 20 ±3 °C (68 ±5 °F) within 30 min and maintaining this temperature for 2 h. c) Reducing the chamber temperature to minus 40 ±3 °C (minus 40 ±5 °F) within 30 min and maintaining this temperature for 4 h. d) Raising the chamber temperature to 20 ±3 °C (68 ±5 °F) within 30 min. e) Repeating the sequence for a further 9 cycles. f) After the 10th cycle, storing the batteries for a minimum of 24 h at 20 ±5 °C (68 ±9 °F) prior to examination.		N/A
28.2	The samples shall not explode or catch fire. In addition, the samples shall not vent or leak as described in 7.2.		N/A
29	Label Permanence Test		N/A
29.1	The purpose of this test is to evaluate the permanence of an adhesive label that has not been subjected to a previous evaluation program. See 30.1.		N/A
29.2	An adhesive label secured to a surface representative of the end use application and is subjected to the following conditioning: a) The label sample is rubbed by hand for 15 s with a piece of cloth soaked with water; and b) The sample is again rubbed for 15 s with a piece of cloth soaked with petroleum spirit.		N/A
29.3	The petroleum spirit to be used for the test is an aliphatic solvent hexane having: a) A maximum aromatics content of 0.1 % by volume; b) A kauributenol value of 29; c) An initial boiling point of approximately 65 °C (149 °F); d) A dry point of approximately 69 °C (156.2 °F); and e) A mass per unit volume of approximately 0.7 kg/L.		N/A
	Exception: As an alternative, it is permitted to use a reagent grade hexane with a minimum of 85 % as nhexane.		N/A
29.4	After the conditioning outlined in 29.2, the sample is to be examined for signs of damage including curing and to determine if the marking is still legible. The sample is also examined to determine if it can be removed by easily by hand from the surface the adhered surface.		N/A
29.5	As a result of the conditioning, the sample label shall remain legible, show no evidence of damage including curling and shall not be able to be able to be easily removed by hand from the adhered surface.		N/A
MARKING AND INSTRUCTIONS			
30	General		P

UL 2054:2021			
Clause	Requirement + Test	Result - Remark	Verdict
30.1	The markings required for compliance to this standard shall be legible and permanent such as etched, adhesive labels, etc. An adhesive-backed label shall comply with the requirements in UL 969, for the intended exposure conditions and surface adhered to.		N/A
	Exception: Adhesive labels may be alternately evaluated to the Label Permanence Test in Section 29.		N/A
30.2	A battery shall be legibly and permanently marked with: a) The manufacturer's name, trade name, or trademark or other descriptive marking by which the organization responsible for the product may be identified; b) A distinctive ("catalog" or "model") number or the equivalent; c) The electrical rating in Vdc and Ah. (Secondary lithium batteries may be marked in Wh rather than Ah); and d) The date or other dating period of manufacture not exceeding any three consecutive months.	See page 4.	P
	Exception No. 1: The manufacturer's identification may be in a traceable code if the product is identified by the brand or trademark owned by a private labeler.		N/A
	Exception No. 2: The date of manufacture may be abbreviated; or may be in a nationally accepted conventional code or in a code affirmed by the manufacturer, provided that the code: a) Does not repeat in less than 10 years, and b) Does not require reference to the production records of the manufacturer to determine when the product was manufactured.		P
30.3	When a manufacturer produces the battery at more than one factory, each battery shall have a distinctive marking to identify it as the product of a particular factory.		N/A
30.4	A battery or the smallest unit package or instructions provided with each battery shall include the following statements or equivalent: a) An attention word, such as "Caution," "Warning," or "Danger." b) A brief description of possible hazards associated with mishandling of the battery, such as burn hazard, fire hazard, explosion hazard. c) A list of actions to take to avoid possible hazards, such as do not crush, disassemble, dispose of in fire, or similar actions, and for primary batteries, do not charge. d) Instructions regarding replacement batteries if the batteries are replaceable by the user.	See page 4.	P

UL 2054:2021			
Clause	Requirement + Test	Result - Remark	Verdict
30.5	A lithium ion battery pack shall be marked with the following or equivalent: "CAUTION: Risk of Fire and Burns. Do Not Open, Crush, Heat Above (manufacturer's specified maximum temperature) or Incinerate. Follow Manufacturer's Instructions." This wording or equivalent shall also be included in the instructions packaged with the battery pack.		N/A
	Exception No. 1: A lithium ion battery pack not provided with an enclosure, need not be marked, but shall include the above wording or equivalent in the instructions provided with the pack.		N/A
	Exception No. 2: If space does not permit marking on the battery, the marking may be on the smallest unit package.		N/A
30.6	The manufacturer's specified charging instructions shall be included for secondary batteries. Primary batteries shall include instructions indicating that the batteries shall not be charged.		P
30.7	A cell or battery that is less than 32 mm (1.25 in) in diameter by 3.8 mm (0.15 in) thick shall include the following marking or equivalent on the smallest unit package or instructions provided with each cell or battery: "Caution – Never put batteries in mouth. If swallowed, contact your physician or local poison control center."		N/A
30.8	Batteries which meet the requirements of the Limited Power Source Test, 15.4, may include the Marking "Limited Power Source" or "LPS".	No "Limited Power Source" "LPS" mark in the label.	N/A

11	TABLE: Short-Circuit Test					P
At 20±5°C						
Sample No.	2307170576A-001	2307170576A-002	2307170576A-003	2307170576A-004	2307170576A-005 (cl.11.11)	
Ambient temp. (°C)	23.4	23.4	23.4	23.4	24.6	
Max. cell casing temp. (°C)	128.3	123.5	125.2	127.5	24.8	
Single fault condition	MOSFET (U2) (PinS1-PinS2) S-C	MOSFET (U2) (PinS1-PinS2) S-C	MOSFET (U2) (PinS1-PinS2) S-C	MOSFET (U2) (PinS1-PinS2) S-C	N/A	
At 55±5°C						
Sample No.	2307170576A-006	2307170576A-007	2307170576A-008	2307170576A-009	2307170576A-0100	
Ambient temp. (°C)	57.4	57.4	57.4	57.4	57.4	
Max. cell casing temp. (°C)	126.2	128.4	125.8	123.9	126.3	
Single fault condition	MOSFET (U2) (PinS1-PinS2) S-C	MOSFET (U2) (PinS1-PinS2) S-C	MOSFET (U2) (PinS1-PinS2) S-C	MOSFET (U2) (PinS1-PinS2) S-C	MOSFET (U2) (PinS1-PinS2) S-C	
Supplementary information: Tmax was recorded on the centre of the cell casing; No explosion or fire, or chemical leak; The temperature of the cell casings does not exceed 150°C (302°F); Cheesecloth and tissue paper not catch fire for the sample tested as cl.11.11 required. No protective devices actuate during the test. S-C=short-circuit.						

12	TABLE: Abnormal Charging Test					P
	3*I _c =0.525A			U _c =4.25V		
Sample No.	2307170576A-011	2307170576A-012	2307170576A-013	2307170576A-014	2307170576A-015	
Ambient temp. (°C)	22.1	22.1	22.1	22.1	22.1	
Max. cell casing temp. (°C)	27.2	27.3	27.2	27.3	27.2	
Single fault condition	MOSFET (U2) (PinS1-PinS2) S-C	MOSFET (U2) (PinS1-PinS2) S-C	MOSFET (U2) (PinS1-PinS2) S-C	MOSFET (U2) (PinS1-PinS2) S-C	MOSFET (U2) (PinS1-PinS2) S-C	

Supplementary information:

T_{max} was recorded on the centre of the cell casing;

No explosion or fire, or chemical leak, no chemical leaks caused by cracking, rupturing or bursting of the cell casing

Charging duration is the time required to reach the manufacturer's specified end-of-charge condition plus seven additional hours.

S-C=short-circuit.

13	TABLE: Abusive Overcharge Test					P
Sample No.	2307170576A-016	2307170576A-017	2307170576A-0188	2307170576A-0199	2307170576A-020	
Charge current (A)	0.35	0.35	0.7	0.7	0.7	
Ambient temp. (°C)	23.1	23.1	23.1	23.1	22.8	
Max. cell casing temp. (°C)	86.8	105.3	121.4	118.2	117.1	
Single fault condition	MOSFET (U2) (PinS1-PinS2) S-C	MOSFET (U2) (PinS1-PinS2) S-C	MOSFET (U2) (PinS1-PinS2) S-C	MOSFET (U2) (PinS1-PinS2) S-C	MOSFET (U2) (PinS1-PinS2) S-C	

Supplementary information:

T_{max} was recorded on the centre of the cell casing;

No explosion or fire;

Charging with 0.7A and 0.35A current, the test is to continue until the cell vents, and the temperature of the internal cell casing reaches steady state conditions or returns to ambient.

S-C=short-circuit.

14	TABLE: Forced-Discharge Test					N/A
Sample No.						
Ambient temp. (°C)						
Max. cell casing temp. (°C)						
Single fault condition						
Supplementary information:						

15	TABLE: Limited Power Source Test					N/A
Circuit output tested: Battery output						
Sample No.	Components	Uoc (V)	I _{sc} (A)		VA	
			Meas.	Limit	Meas.	Limit
Supplementary information:						

16/17	TABLE: Battery Pack Component Temperature Test and Battery Pack Surface Temperature Test					P
16: Battery Pack Component Temperature Test						
Sample No.	2307170576A-021		2307170576A-022		Limited T	
Testing Process	Charging	Discharging	Charging	Discharging	Charging	Discharging
PCB near U1	25.4	31.5	26.1	29.4	130+21.6-45=106.6	130+22.2-60=92.2
PCB near U2	26.2	33.1	26.0	29.3	130+21.6-45=106.6	130+22.2-60=92.2
Lead wire	23.9	26.7	24.1	25.1	105+21.6-45=81.6	105+22.2-60=67.2
Cell body	27.5	36.8	27.6	34.2	Ref.	Ref.
Connector	23.6	26.5	23.8	24.9	85+21.6-45=61.6	85+22.2-60=47.2
Ambient	21.6	22.3	22.4	22.2	--	--
17: Battery Pack Surface Temperature Test						
Sample No.					Limited T	
Testing Process	Charging	Discharging	Charging	Discharging	Charging	Discharging
	--	--	--	--	--	--

Supplementary information:

Measurement temperature T not exceed ($T_{max} + T_{amb} - T_{ma}$);

Temperatures on external accessible surfaces of the pack not exceed the limits outlined in Table 17.1.

For input loading, the battery charged with 0.525A and 4.25V;

For output loading, the battery discharged with 0.8A until 3.0V.

Max. cell voltage during input test is 4.25V, not exceed the upper limit of the charging voltage specified by the cell manufacturer.

23	TABLE: Steady Force Test			N/A
Ambient temperature: °C				
Sample No.				
Mass before test (g)				
Mass after test (g)				
Mass loss ratio (%)				
Supplementary information:				

24	TABLE: Mold Stress Relief Test			N/A
Ambient temperature: °C				
Sample No.				
Mass before test (g)				
Mass after test (g)				
Mass loss ratio (%)				
Supplementary information:				

25	TABLE: Drop Impact Test for model			N/A
Ambient temperature: °C				
Sample No.				
Mass before test (g)				
Mass after test (g)				
Mass loss ratio (%)				
Supplementary information:				

Critical Components					
Material: e.g. external enclosure, PCB, closed-end connector, sleeves, cord anchorage etc					
Components with winding: e.g. motor, transformer, magnetic coil etc.					
Other components: e.g. switch, thermostat, heater, plug, internal wire, capacitor, relay, varistor etc.					
Object/part No.	Manufacturer/ trademark	Type/ model	Technical data	Standard	Mark(s) of conformity
Cell	DNK POWER COMPANY LIMITED	DNK 701535	3.7V, 350mAh, 1.295Wh	UL 1642:2020 R10.22	Certificate No.: US 72302558 01
Protection IC (U1)	ABLIC Inc.	S-8261DAA-M6T1U	Overcharge detection voltage: 4.28±0.02V, overdischarge detection voltage: 3.0V±0.05V, T _{op} : -40°C ~ +85°C	--	Tested with appliance
MOSFET (U2)	Shenzhen Developer Microelectronics Co., Ltd	DP8205	V _{DS} : 20V, V _{GS} : ±12V, I _D : 5A @ T _J =25°C, T _J , T _{STG} : -55°C ~ +150°C	--	Tested with appliance
PCB	Shenzhen Lutongda Technology Co Ltd	LTD-D	V-0, 130°C	UL 796 UL 94	UL E486889
PCB (Alternative)	Interchangeable	Interchangeable	Min. V-0, Min.130°C	UL 796 UL 94	UL approved
Wiring	Dongguan Mingxiu Electronics Technology Co Ltd	3302	30AWG, 105°C, 30Vac	UL 758	UL E492150
Wiring (Alternative)	Interchangeable	Interchangeable	30AWG Minimum, 105°C, 30Vac	UL 758	UL approved
Connector	HIROSE ELECTRIC CO., LTD.	DF57-2S	2pins, 100V, 2.5A, Operating temperature range: -55°C ~ 85°C	UL 1977	UL E52653

--End of main report--

Attachment 2

Equipment list

CN23GON0 001

Page 1 of 1



www.lcs-cert.com

Produkte
Products

	Eq. No.	Name	Manufacturer	Model No.	Date of Calibration	Date of next Calibration
<input checked="" type="checkbox"/>	LCS-S-222	Temperature recorder	Agilent	34970A	2023/09/19	2024/09/18
<input checked="" type="checkbox"/>	LCS-S-105	Internal Resistance Tester	TESTPAD ELECTRONIC CO LTD	BTS-100	2023/09/19	2024/09/18
<input checked="" type="checkbox"/>	LCS-S-181	Temperature recorder	Agilent	34972A	2023/09/19	2024/09/18
<input checked="" type="checkbox"/>	LCS-S-229	Shermal shock test chamber	Taian	TA-YQ270B	2023/09/18	2024/09/17
<input checked="" type="checkbox"/>	LCS-S-241	DC electronic Load	ITECH ELECTONLC CO.,LTD.	IT8510	2023/09/19	2024/09/18
<input checked="" type="checkbox"/>	LCS-S-281	Digital multimeter	F15B+	FLUKE	2023/09/19	2024/09/18
<input checked="" type="checkbox"/>	LCS-S-282	Digital multimeter	F15B+	FLUKE	2023/09/19	2024/09/18
<input checked="" type="checkbox"/>	LCS-S-284	Battery Charge/Discharge Tester	Xinwei	CT-4008-20V6A-A	2023/09/19	2024/09/18
<input checked="" type="checkbox"/>	LCS-S-287	DC source	ITECH ELECTONLC CO.,LTD.	IT6512	2023/09/19	2024/09/18
<input checked="" type="checkbox"/>	LCS-S-288	DC source	ITECH ELECTONLC CO.,LTD.	IT6512	2023/09/19	2024/09/18
<input checked="" type="checkbox"/>	LCS-S-295	DC source	ITECH ELECTONLC CO.,LTD.	IT6512	2023/09/19	2024/09/18
<input checked="" type="checkbox"/>	LCS-S-293	DC source	ITECH ELECTONLC CO.,LTD.	IT6512	2023/09/19	2024/09/18
<input checked="" type="checkbox"/>	LCS-S-292	DC source	ITECH ELECTONLC CO.,LTD.	IT6512	2023/09/19	2024/09/18
<input checked="" type="checkbox"/>	LCS-S-297	Digital temperature hygrometer	VICTOR	HS-1	2023/09/19	2024/09/18
<input checked="" type="checkbox"/>	LCS-S-298	Digital temperature hygrometer	VICTOR	HS-1	2023/09/19	2024/09/18
<input checked="" type="checkbox"/>	LCS-S-299	Digital temperature hygrometer	VICTOR	HS-1	2023/09/19	2024/09/18
<input checked="" type="checkbox"/>	LCS-S-505	Temperature controlled Battery Short Circuit Tester	Xiangmin	XM-WK002	2023/06/08	2024/06/07
<input checked="" type="checkbox"/>	LCS-S-506	Temperature controlled Battery Short Circuit Tester	Xiangmin	XM-WK002	2023/06/08	2024/06/07
<input checked="" type="checkbox"/>	LCS-S-507	Temperature controlled Battery Short Circuit Tester	Xiangmin	XM-WK002	2023/06/08	2024/06/07
<input checked="" type="checkbox"/>	LCS-S-508	Temperature controlled Battery Short Circuit Tester	Xiangmin	XM-WK002	2023/06/08	2024/06/07
<input checked="" type="checkbox"/>	LCS-S-514	Temperature controlled Battery Short Circuit Tester	Safety	AG383T55	2023/09/19	2024/09/18
<input checked="" type="checkbox"/>	LCS-S-555	Electronic load	Edks	IT8512A+	2023/04/18	2024/04/17

Shenzhen LCS Compliance Testing Laboratory Ltd.

Room 101, 201, Building A and Room 301, Building C, Juji Industrial Park, Yabianxueziwei, Shajing Street, Bao'an District, Shenzhen, Guangdong, China

Product: Li-ion Polymer Battery

Type Designation: DNK 701535

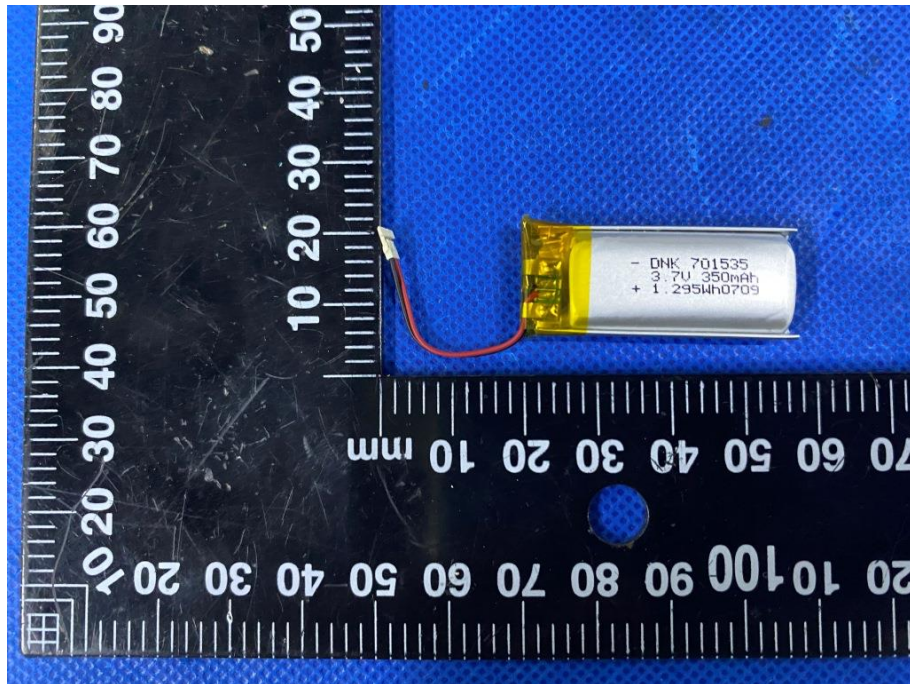

Figure 1 Front view of battery

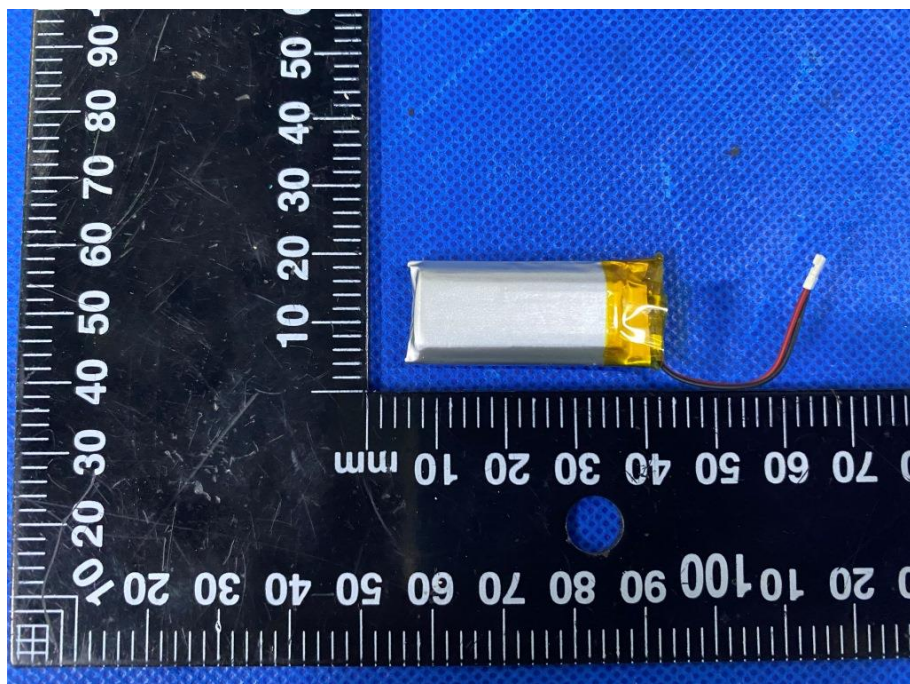

Figure 2 Back view of battery

Product: Li-ion Polymer Battery

Type Designation: DNK 701535

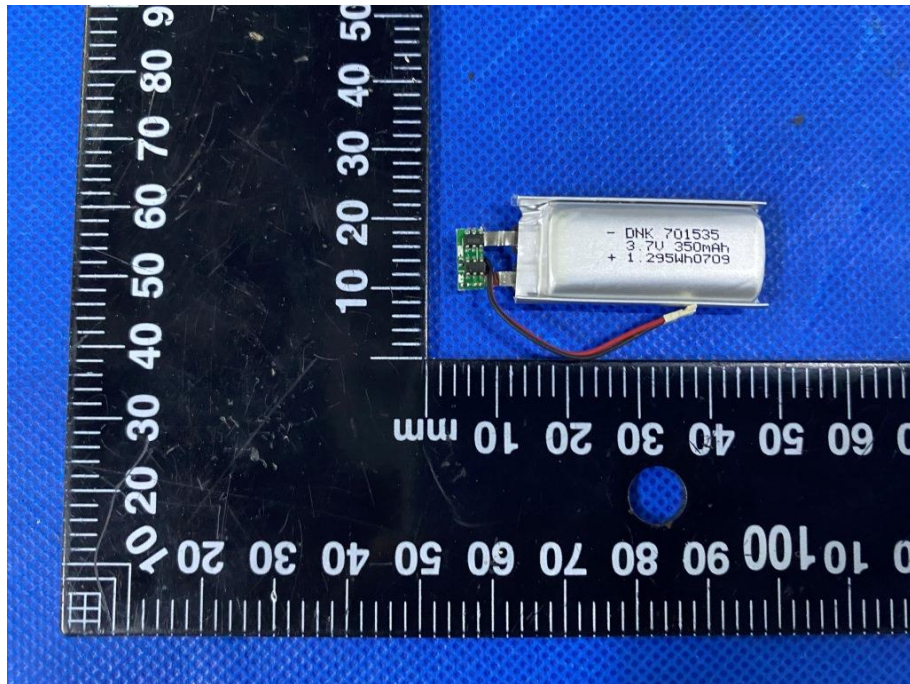

Figure 3 Internal view-1 of battery

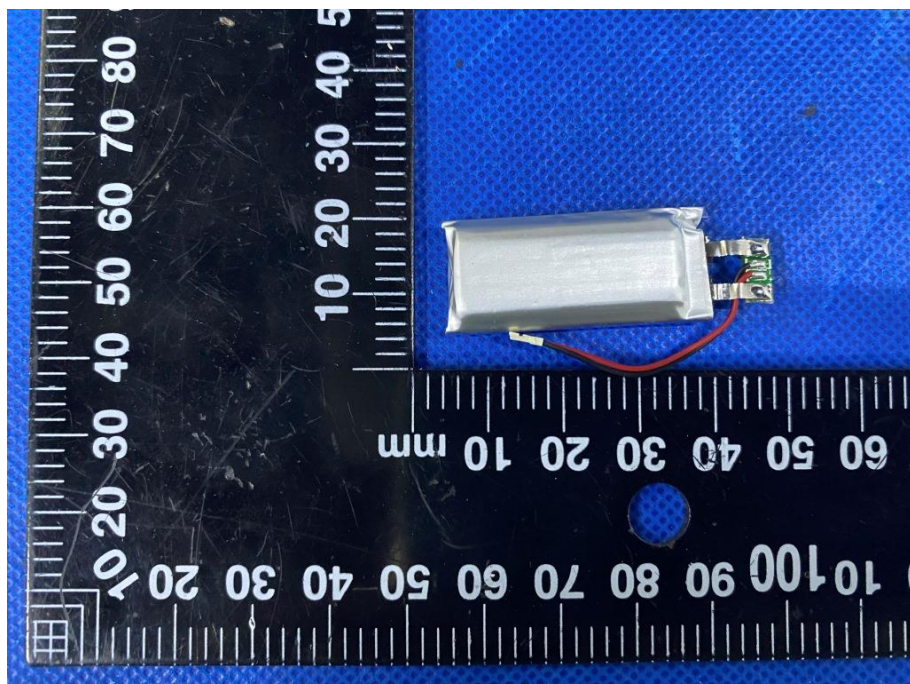

Figure 4 Internal view-2 of battery

Product: Li-ion Polymer Battery

Type Designation: DNK 701535

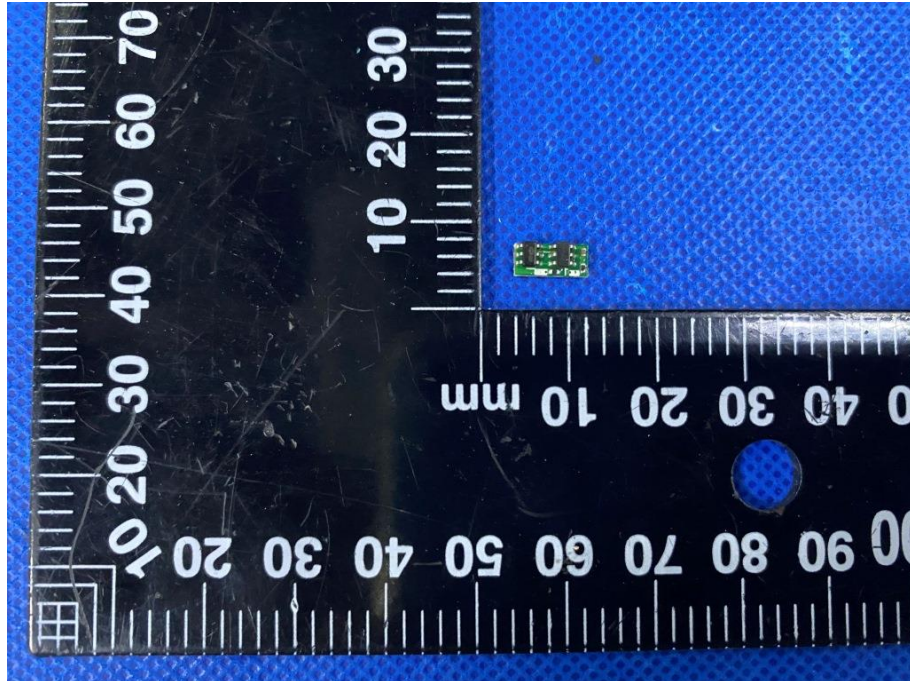

Figure 5 Front view of PCM

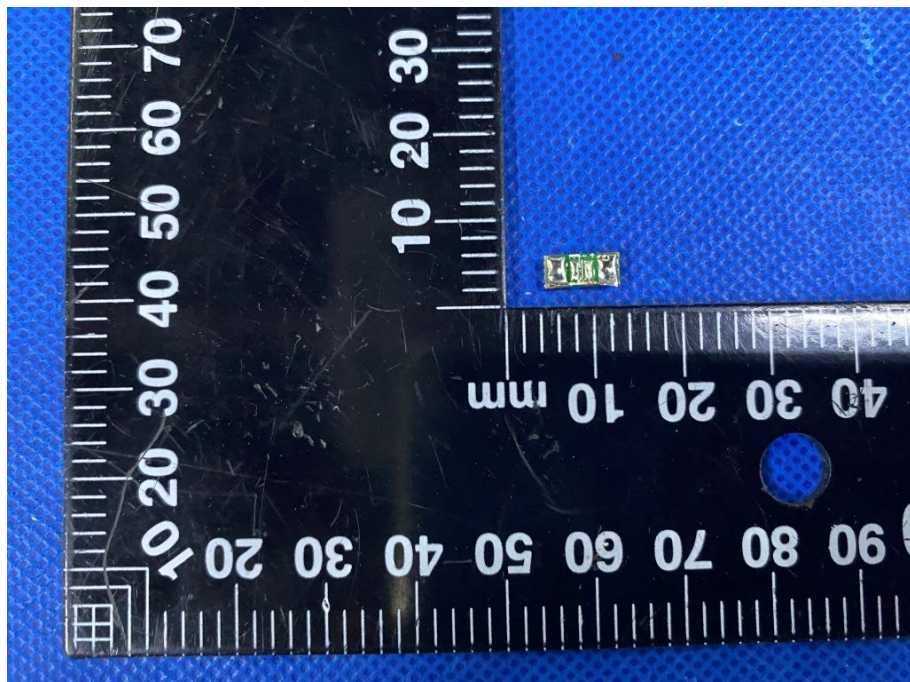

Figure 6 Back view of PCM

Product: Li-ion Polymer Battery

Type Designation: DNK 701535

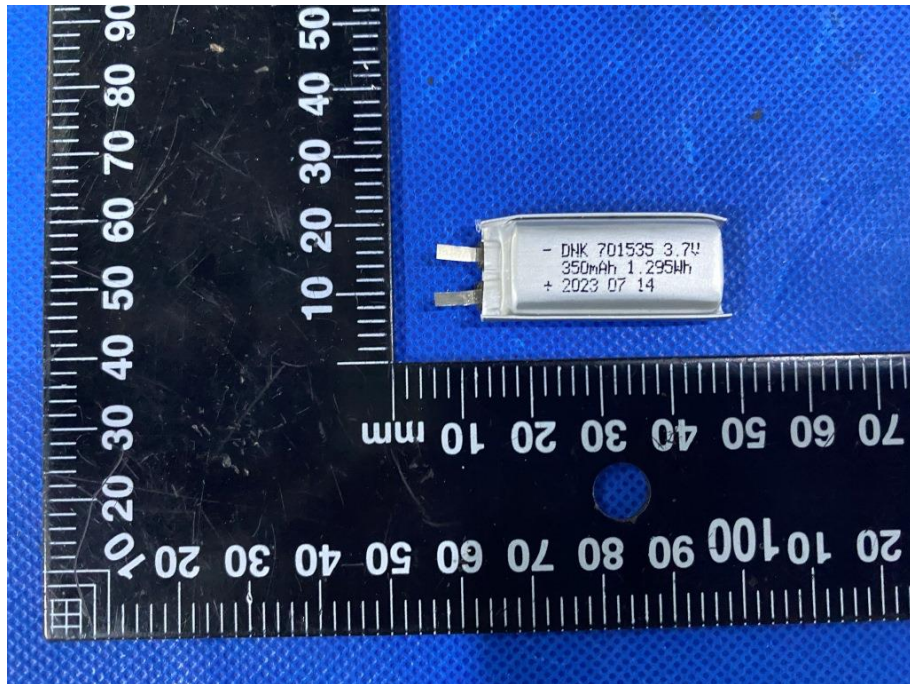

Figure 7 Front view of cell

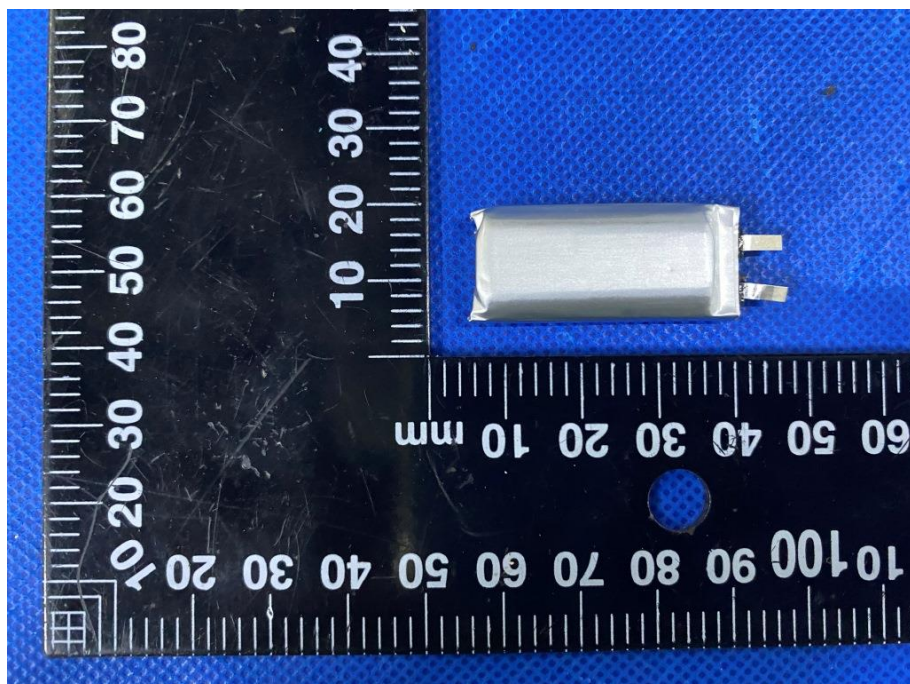

Figure 8 Back view of cell