



Spec. No.	INR21700-48X	Version No.	0.0
-----------	--------------	-------------	-----

# Specification of Product

- 1. Customer : General
- 2. Product : Lithium-ion Rechargeable Cell
- 3. SDI Model : INR21700-48X (tube cell)
- 4. Approved by

Division			
Signature			
Date	/ /	/ /	/ /

5. Date of Application (YY/MM/DD) : 2020/04/28

6. Supplier : **SAMSUNG SDI Co., Ltd.**  
Battery Business Division

Issued	Checked	Approved



Spec. No.	INR21700-48X	Version No.	0.0
-----------	--------------	-------------	-----

**Revision history**

Revision No.	Date (yr-m-d)	Page	Item	Description	Changes / Author
v0.0	'19-05-28			First version	DS, KIM
V0.1	20-04-28			Change cell diameter dimesion and charge voltage condition for cycle life Add a 1/3 rated capacity	JH, Lee EH, Yoon

Spec. No.	INR21700-48X	Version No.	0.0
-----------	--------------	-------------	-----

## 1. Scope

This product specification has been prepared to specify the rechargeable lithium-ion cell ("Cell" or "Cells") to be supplied to the customer by Samsung SDI Co., Ltd. ("Samsung SDI")

## 2. Description and Model

- 2.1 Description            Cell (lithium-ion rechargeable cell)  
 2.2 Model                    INR21700-48X (tube cell)

## 3. Nominal Specifications (\*1)

Item	Specification
3.1 Standard discharge Capacity	Min 4,650mAh, Typ. 4,800mAh - Charge: 0.33C(1584mA),4.2V, 0.025C(120mA) cutoff @ RT - Discharge : 0.2C(960mA), 2.5V cutoff @ RT (Avoid direct wind), * 1C = 4,800mA
3.2 Rated discharge capacity	Min. 4,650mAh, Typ. 4,800mAh - Charge: 0.33C(1584mA),4.2V, 0.025C(120mA) cutoff @ RT - Discharge : 1.0C(4,800mA), 2.5V cutoff @ RT (Avoid direct wind), *1C = 4,800mA
3.2.2 Rated discharge capacity	Min. <b>4,650mAh</b> , Typ. <b>4,800mAh</b> - Charge: 0.33C(1,584mA),4.2V, 0.025C(120mA) cutoff @ RT - Discharge : <b>0.33C(1,584mA)</b> , 2.5V cutoff @ RT (Avoid direct wind) *1C = 4,800mA
3.3 Max charging Voltage	4.2V ( <b>4.10V</b> for cycle life)
3.4 Nominal Voltage	Typ. 3.64V
3.5 Charging Method	CC-CV (constant voltage with limited current)
3.6 Charging Current rate	0.33C (1,584mA)
3.7 Discharge Cut-off Voltage	2.5V (3.0V for cycle life)
3.8 Cycle life	Capacity ≥ 70% @ after 3,000cycles (70% of the Initial Capacity @ RT) - Charge : 1.0C(4,800mA), <b>4.10V</b> , CCCV 0.05C(240mA) cut-off @ RT - Discharge: 1.0C(4,800mA), 3.0V cut-off @ RT
3.9 Cell Weight	68.0g ± 1.5g
3.10 Cell Dimension	Cell height: 70.65 ± 0.15mm Diameter: Φ 21.15 ± <b>0.20</b> mm
3.11 Operating Temperature(*2) (Cell Surface Temperature)	Charge : 0 to 50°C (refer to 14. operating charging guide) Discharge : -30 to 60°C
3.12 Recovery 80% after storage(*3)	1 year : -20~25°C 3 months : -40~45°C 1 month : -40~60°C



Spec. No.	INR21700-48X	Version No.	0.0
-----------	--------------	-------------	-----

Note (\*1): Protection function of the battery pack should be set within the specified charge, discharge and temperature range in the Cell Specification.

Note (\*2): Operating Charging Guide (See page 14)

Note (\*3): If the cell is kept as ex-factory status (30% of charge), the capacity recovery rate is more than 80%.

Spec. No.	INR21700-48X	Version No.	0.0
-----------	--------------	-------------	-----

#### 4. Outline Dimensions

See the Fig. 1

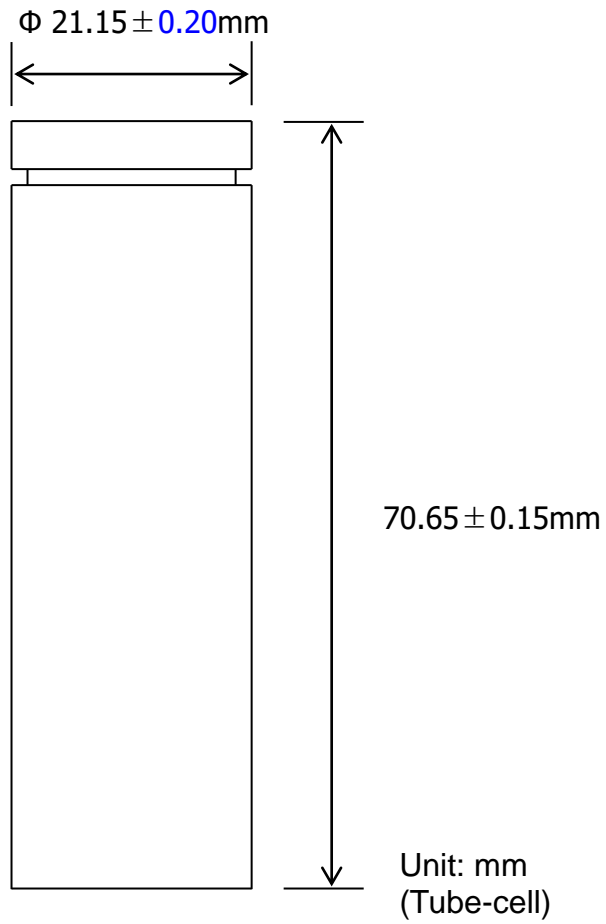

**Fig. 1 Outline Dimensions of INR21700-48X**

Spec. No.	INR21700-48X	Version No.	0.0
-----------	--------------	-------------	-----

## 5. Appearance

There shall be no such defects as scratch, rust, discoloration, leakage which may adversely affect commercial value of the cell.

### 5.1 2D Marking

#### (1) Purpose

- To reinforce detecting cell defects through comparing OCV before pack Manufacturing
- Check the difference of OCV between OCV of 2D barcode and OCV of Customer sorting.

#### (2) 2D Marking Information

- Cell batch number & Serial number (for SDI Internal)
- IR/OCV in outgoing inspection (for Customer)

#### (3) Size

- Normal 2D: 6.4mm \* 6.4mm ( $\pm 1$ mm)
- GBT 2D: 5.5mm \* 5.5mm ( $\pm 1$ mm)

### 5.2. Appearance (TBD)

Spec. No.	INR21700-48X	Version No.	0.0
-----------	--------------	-------------	-----

## 6. Standard Test Conditions

### 6.1 Environmental Conditions

Unless otherwise specified, all tests stated in this specification are conducted at temperature  $25\pm 3^{\circ}\text{C}$  and humidity under 60%.

### 6.2 Measuring Equipment

#### (1) Amp-meter and Volt-meter

The amp-meter and volt-meter should have an accuracy of the grade 0.5mA and mV or higher.

#### (2) Slide caliper

The slide caliper should have 0.01 mm scale.

#### (3) Impedance meter

The impedance meter with AC 1kHz should be used.

## 7. Characteristics

### 7.1 Standard Charge

This "Standard Charge" means charging Cell CCCV with charge current of 0.33C (1,584mA) and constant voltage 4.2V and 0.025C(120mA) cut-off in CV mode at  $25^{\circ}\text{C}$ .

### 7.2 Standard Discharge Capacity

The standard discharge capacity is the initial discharge capacity of Cell, which is measured with discharge current of 0.2C(960mA) with 2.50V cut-off at  $25^{\circ}\text{C}$  within 10 min after the Standard charge.

$$\text{Standard Discharge Capacity} \geq 4,650\text{mAh}$$

### 7.3 Initial internal impedance

Initial internal impedance measured at AC 1kHz after Standard charge.

$$\text{Initial internal impedance} \quad 13.0\pm 5.0\text{m}\Omega$$

Spec. No.	INR21700-48X	Version No.	0.0
-----------	--------------	-------------	-----

#### 7.4 Temperature Dependence of Discharge Capacity

Discharge capacity comparison at each temperature, measured with discharge constant current 0.2C(960mA) and 2.5V cut-off with follow temperature after the standard charging at 25°C.

Charge temperature	Discharge temperature					
25°C	-20°C	-10°C	0°C	25°C	45°C	60°C
Cut-off voltage	2.5V	2.5V	2.5V	2.5V	2.5V	2.5V
Relative capacity	70%	75%	85%	100%	100%	95%

Note: If charge temperature and discharge temperature is not the same, the interval for temperature change is 4 hours.

Percentage as an index of the Standard discharge capacity (=4,650mAh) is 100%

#### 7.5 Temperature Dependence of Charge Capacity

Capacity comparison at each temperature, measured with discharge constant current 0.2C(960mA) and 2.5V cut-off at 25°C after the standard charge is as follow temperature.

	Charge temperature			Discharge temperature
	0°C	25°C	50°C	
Relative Capacity	90%	100%	100%	25°C

Note: If charge temperature and discharge temperature is not the same, the interval for temperature change is 4 hours.

Percentage as an index of the standard discharge capacity (=4,650mAh) is 100%.

#### 7.6 Charge Rate Capabilities

Discharge capacity is measured with constant current 0.2C(960mA) and 2.5V cut-off after the cell is charged with 4.2V at 25°C as follows.

	Charge Condition		
Current	0.33C (1,584mA)	0.5C (2,400mA)	1.0C (4,800mA)
Cut-off	0.025C	0.025C	0.025C
Relative Capacity	100%	100%	95%

Note: Percentage as an index of the standard discharge capacity (=4,650mAh) is 100%.

Spec. No.	INR21700-48X	Version No.	0.0
-----------	--------------	-------------	-----

### 7.7 Discharge Rate Capabilities

Discharge capacity is measured with the various currents in under table and 2.5V cut-off after the Standard charge at 25°C.

Current	Discharge Condition				
	0.2C (960mA)	0.5C (2,400mA)	1.0C (4,800mA)	1.5C (7,200mA)	2C (9600mA)
Relative Capacity	100%	100%	100%	85%	80%

Note: Percentage as an index of the standard discharge capacity (=4,650mAh) is 100%.

### 7.8 Cycle Life

Each cycle is an interval between the charge [charge current 1.0C(4,800mA)] with 4.10V 0.05C cut-off and the discharge [discharge current 1C(4,800mA)] with 3.0V cut-off.

Capacity after 3000 cycles. Capacity  $\geq$  70% of Initial capacity

### 7.9 Storage Characteristics 1

After storage for 28days at RT with the standard charge, capacity is measured with discharge current 1.0C (4,800mA) with 2.50V cut-off , charge current 0.33C (1,584mA) 0.025C cut-off with 4.2V and discharge current 1.0C (4,800mA) with 2.50V cut-off at 25°C, .

Capacity recovery (after the storage)  $\geq$  90% of Initial discharge capacity

### 7.10 Storage Characteristics 2

After storage for 7days at  $55 \pm 2$  °C with the standard charge, capacity is measured with discharge current 1.0C (4,800mA) with 2.50V cut-off , charge current 0.33C (1,584mA) 0.025C cut-off with 4.2V and discharge current 1.0C (4,800mA) with 2.50V cut-off at 25°C,

Capacity recovery (after the storage)  $\geq$  90% of Initial discharge capacity

### 7.10 Status of Cell as of ex-factory

Cell should be shipped in 3.530V ~ 3.630V Charging voltage range.

## 8. Safety

: UN38.3

Spec. No.	INR21700-48X	Version No.	0.0
-----------	--------------	-------------	-----

### 9. Warranty

Samsung SDI warrants that Cell will be free from defects in manufacturing for a period of 24 months from the date of shipping ("Warranty Period"). In case of defects, Samsung SDI will only replace the affected Cell. However, Samsung SDI shall not be liable for if (i) Cell was improperly installed, repaired, altered or otherwise modified (other than by Samsung SDI), (ii) Cell was subjected to misuse, abuse, negligence or accident, or (iii) Cell was used, handled, stored, sold or distributed in a manner contrary or inconsistent to the handling /use instructions provided in this product specification sheet and the customer environment test guidelines (if any).

### 10. Packaging

See Fig.2: Package Drawing

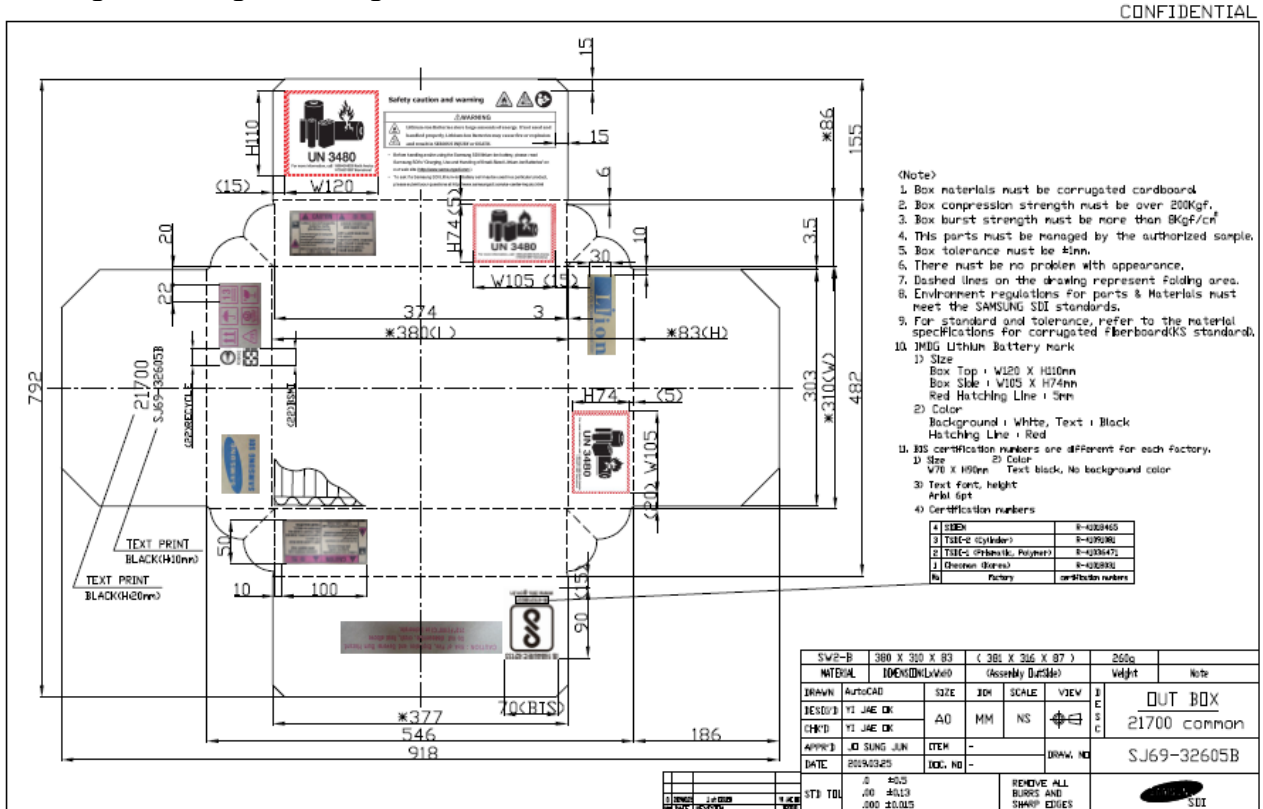

Fig. 2-1. Outer box package drawing.

Spec. No.	INR21700-48X	Version No.	0.0
-----------	--------------	-------------	-----

CONFIDENTIAL

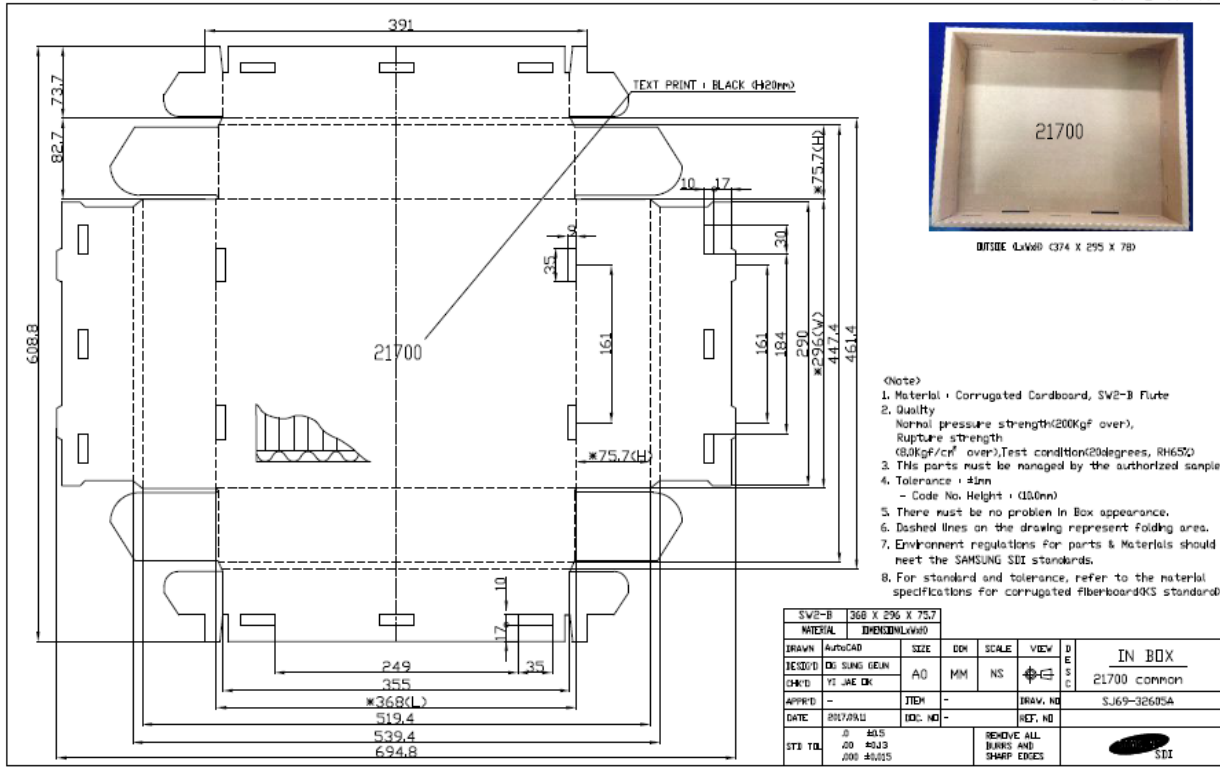

Fig. 2-2. Inner box package drawing.

Spec. No.	INR21700-48X	Version No.	0.0
-----------	--------------	-------------	-----

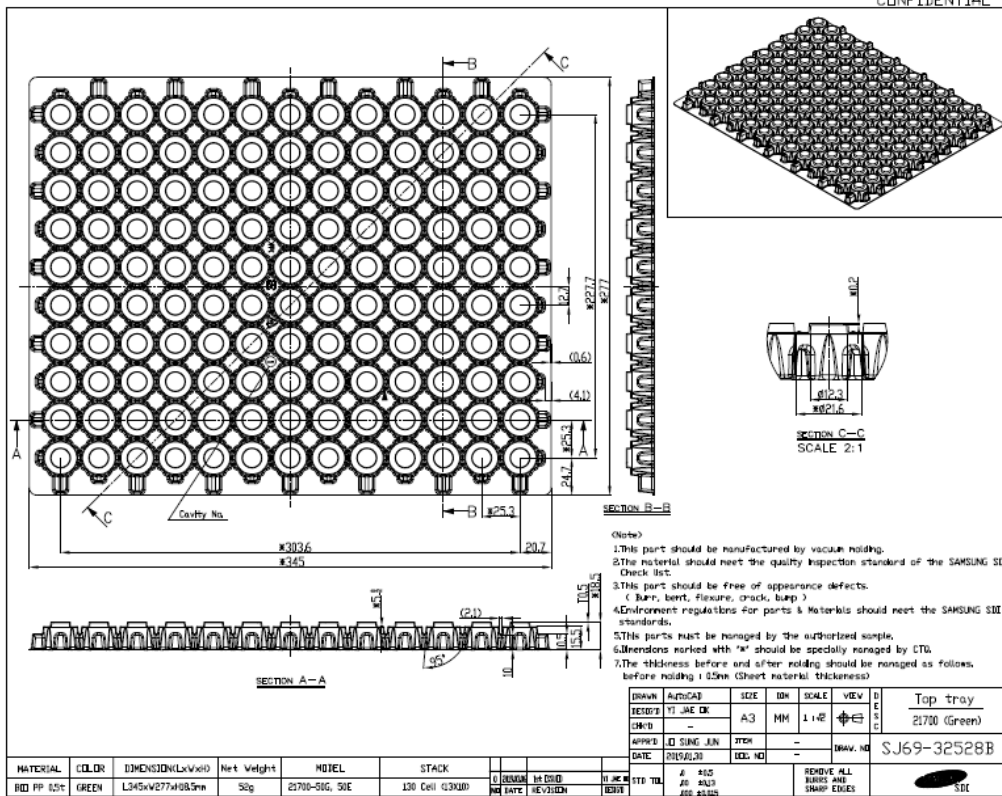

Fig. 2-3. Upper tray drawing.

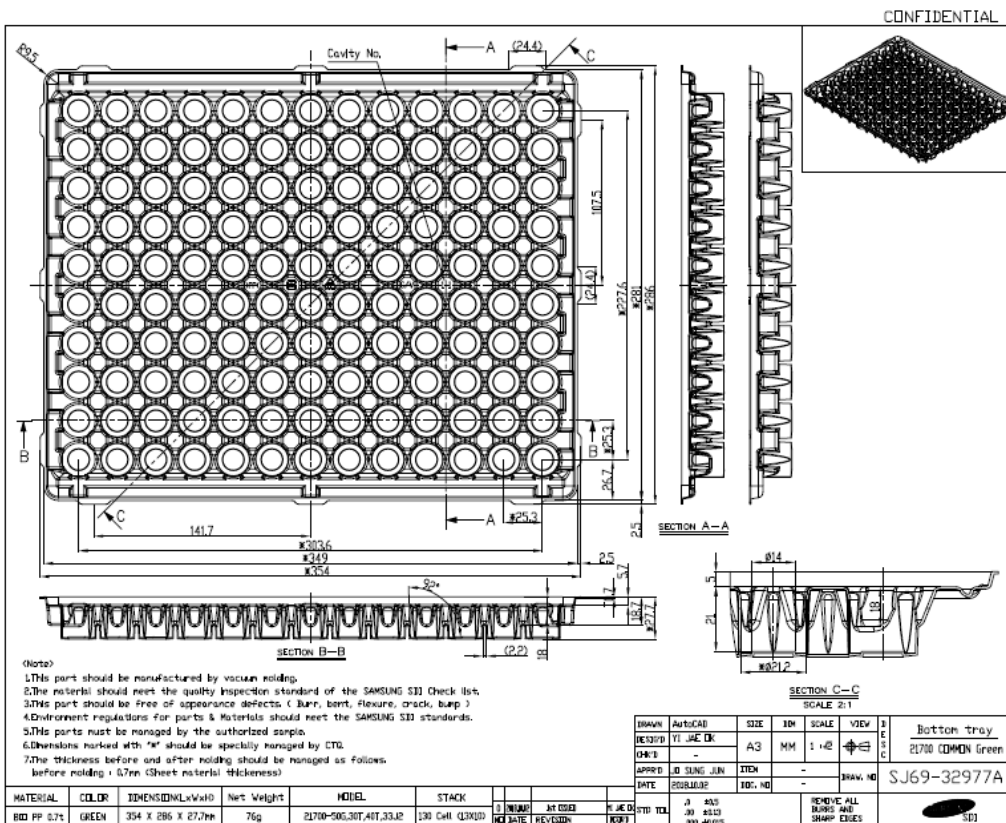

Fig. 2-4. Bottom tray drawing.

Spec. No.	INR21700-48X	Version No.	0.0
-----------	--------------	-------------	-----

CONFIDENTIAL 2019-03-25

No	CODE/No.	CODE NAME	SPEC	QTY		NOTE
				OCEAN	UNIT	
<b>BOX</b>						
1	INR21700	CELL	CYLINDER TYPE	130	PCS	-
2	SJ69-32605A	IN BOX	SWZ-B	1	PCS	-
3	SJ69-32977A	TRAY (BOTTOM)	PP	1	PCS	-
4	SJ69-32528B	TRAY (TOP)	PP	1	PCS	-
5	SJ69-32805B	OUT BOX	SWZ-B	1	PCS	-
6	SJ02-01849A	SILICAGEL	SI	2	PCS	-
7	SJ69-33114C	BAG (AUTO)	LDP	0.001	ROL	-
8	SJ02-00684B	TAPE (AUTO)	OPP	0.001	ROL	-
9	SJ68-00146G	LABEL(PRODUCT)	ART PAPER	1	PCS	-
<b>PALLET</b>						
P1	SJ69-32179A	PALLET	PP	1	PCS	EU
P2	SJ69-00338B	PACKING CAP	DW1-AB	1	PCS	-
P3	SJ68-01560A	LABEL(SHIP LOT)	ART PAPER	1	PCS	-
P4	SJ68-01561A	LABEL(PALLET)	ART PAPER	1	PCS	-
P5	SJ68-00145B	LABEL(STACK)	ART PAPER	2	PCS	-
P6	SJ68-00144C	LABEL(INSPECTION)	ART PAPER	2	PCS	-
P7	SJ69-31255A	CORNER BLOCK(L)	C.F.B	4	PCS	-
P8	SJ69-31256A	CORNER BLOCK(R)	C.F.B	4	PCS	-
P9	SJ69-32417A	WRAP (MANUAL)	LLDPE	0.011	ROL	-
P10	SJ69-32562A	WRAP (AUTO)	LLDPE	0.051	ROL	-
P11	SJ69-31449A	SHEET	LDPE	1	PCS	-
P12	SJ72-00338B	BAND	PP	0.018	ROL	-

CELL	OCEAN	UNIT	NOTE
QTY	130	Cell/ Box	
	12,870	Cell/ Pallet	
	99	Box/ Pallet	3x3x11 (H=1.1m)
NET WEIGHT	69.5	g/ Cell	Max
	90	kg/ Box	
	894	kg/ Pallet	

**NOTE**

- This packaging drawings for Ocean.
- Do not double pallet stack.
- The pallet box quantity is based on full pallet.
- This packaging drawing is used in common with the following models.

INR21700-S0G  
INR21700-S0E

NO	DATE	REVISION	REASON
1	'19-03-25	1st ISSUED	-
2			

DESIGN	YI JAEOK	DIM / SIZE / SCALE	
CHKD	YI JAEOK	MM / A3 / N5	
APPRD	JO SUNGJUN	DWG No.	
DATE	2019-03-25		

PACKAGING DRAWING	
[CYLINDER CELL]	
OCEAN(KOREA)	
BUYER	
CELL	INR21700

THIS DRAWING IS COPYRIGHT IT MUST NOT BE COPIED, REPRODUCED OR OTHERWISE MADE USE OF WITHOUT THE WRITTEN PERMISSION OF SAMSUNG SDI CO.LTD.

**Fig. 2-5. Pallet packaging process**

Spec. No.	INR21700-48X	Version No.	0.0
-----------	--------------	-------------	-----

## 11. INR21700-48X Performance Usable Range

ⓘ Usable Voltage Range Not Permitted to Charge for Operating Voltage Check Need to Minimum DC/AC Inverter Operating Voltage Check

Cell Surface	Charge Max Voltage (V)			Discharge Min Voltage (V)		
	Operating Limit	Pulse Limit	Safety Limit	Operating Limit	Pulse Limit	Safety Limit
-30°C~-20°C	4.100V	4.150V	4.250V	3.000V	2.500V	2.000V
-20°C~-10°C	4.100V	4.150V	4.250V	3.000V	2.500V	2.000V
-10°C~0°C	4.100V	4.150V	4.250V	3.000V	2.500V	2.000V
0°C~10°C	4.100V	4.150V	4.250V	3.000V	2.850V	2.500V
10°C~25°C	4.100V	4.150V	4.250V	3.000V	2.850V	2.500V
25°C~32°C	4.100V	4.150V	4.250V	3.000V	2.850V	2.500V
32°C~40°C	4.100V	4.150V	4.250V	3.000V	3.000V	2.500V
40°C~50°C	4.000V	4.150V	4.200V	3.000V	3.000V	2.500V
50°C~60°C	4.000V	4.150V	4.200V	3.000V	3.000V	2.500V

- This above table has been prepared to help minimize field cycle degradation, therefore must be reflected in the customer's module/pack design.

### ⓘ Safety Current Limit

30sec Discharge Current Limit(A) \*SOC0~100 : 4.2-2.5V

Temp.	SOC										
	0	10	20	30	40	50	60	70	80	90	100
-30	0.0	0.0	0.0	2.0	2.0	2.0	3.0	4.0	4.0	4.0	4.0
-20	0.0	1.0	4.0	6.0	6.0	7.0	7.0	8.0	8.0	9.0	9.0
-10	0.0	2.0	8.0	11.0	13.0	14.0	15.0	16.0	17.0	18.0	18.0
0	0.0	5.0	12.0	16.0	18.0	19.0	21.0	22.0	23.0	25.0	25.0
10	0.0	8.0	17.0	22.0	24.0	26.0	28.0	30.0	31.0	33.0	33.0
25	0.0	12.0	24.0	30.0	34.0	36.0	39.0	42.0	43.0	44.0	44.0
40	0.0	12.0	24.0	30.0	34.0	36.0	39.0	42.0	43.0	44.0	44.0
50	0.0	12.0	24.0	30.0	34.0	36.0	39.0	42.0	43.0	44.0	44.0
60	0.0	7.5	14.0	18.0	20.0	20.0	25.0	25.0	25.0	30.0	30.0

10sec Charge Current Limit(A)

Temp.	SOC											
	0	10	20	30	40	50	60	70	80	90	100	
-30	0.25	0.25	0.25	0.25	0.25	0.25	0.25	0.25	0.25	0.20	0.15	0.00
-20	1.00	1.00	1.00	1.00	0.75	0.75	0.75	0.50	0.30	0.30	0.00	0.00
-10	9.00	8.00	8.00	5.00	5.00	4.00	3.00	2.00	1.00	0.60	0.00	0.00
0	12.0	12.0	12.0	10.0	8.00	8.00	6.00	4.00	2.0	1.0	0.00	0.00
10	17.0	17.0	14.0	14.0	14.0	12.0	10.0	7.0	4.0	2.0	0.00	0.00
25	21.0	21.0	21.0	21.0	20.0	17.0	13.0	10.0	6.0	4.0	0.00	0.00
40	21.0	21.0	21.0	21.0	20.0	17.0	13.0	10.0	6.0	4.0	0.00	0.00
50	21.0	21.0	21.0	21.0	20.0	17.0	13.0	10.0	6.0	4.0	0.00	0.00
60	21.0	21.0	21.0	21.0	20.0	17.0	13.0	10.0	6.0	4.0	0.00	0.00

Continuous(>120s) Discharge Current Limit(A)

Temp.	SOC										
	0	10	20	30	40	50	60	70	80	90	100
-30	0.0	0.5	0.5	0.5	0.8	0.8	1.5	1.5	1.5	1.5	1.5
-20	0.0	2.3	2.3	2.3	3.0	3.0	3.0	3.0	3.0	3.0	3.0
-10	0.0	2.3	3.0	3.0	4.5	4.5	4.5	4.5	4.5	4.5	4.5
0	0.0	6.0	7.5	7.5	7.5	7.5	7.5	7.5	7.5	7.5	7.5
10	0.0	8.0	11.0	12.0	12.0	12.0	12.0	12.0	12.0	12.0	12.0
25	0.0	6.0	11.0	15.0	15.0	15.0	18.0	18.0	18.0	18.0	18.0
40	0.0	6.0	11.0	15.0	15.0	15.0	18.0	18.0	18.0	18.0	18.0
50	0.0	6.0	7.5	7.5	7.5	7.5	7.5	7.5	7.5	7.5	7.5
60	0.0	5.0	5.0	5.0	5.0	5.0	5.0	5.0	5.0	5.0	5.0

Continuous Charge Current Limit(A)

Temp.	SOC											
	0	10	20	30	40	50	60	70	80	90	100	
-30	0.10	0.10	0.10	0.10	0.10	0.10	0.10	0.10	0.05	0.03	0.01	0.00
-20	0.20	0.20	0.20	0.20	0.20	0.20	0.20	0.20	0.08	0.05	0.03	0.00
-10	3.00	1.50	1.50	0.50	0.50	0.30	0.30	0.10	0.10	0.05	0.00	0.00
0	5.00	3.00	3.00	1.00	1.00	0.50	0.50	0.25	0.25	0.10	0.00	0.00
10	7.50	7.50	7.50	3.50	3.50	2.50	2.50	2.50	2.50	2.50	0.00	0.00
25	15.00	15.00	15.00	7.00	7.00	5.00	3.00	3.00	3.00	3.00	0.00	0.00
40	18.00	18.00	18.00	18.00	16.00	12.00	8.00	6.00	6.00	6.00	0.00	0.00
50	5.00	5.00	5.00	5.00	5.00	5.00	3.00	3.00	3.00	3.00	0.00	0.00
60	0.00	0.00	0.00	0.00	0.00	0.00	0.00	0.00	0.00	0.00	0.00	0.00

- This above table has been prepared to help minimize only safety cell damage, not field cycle degradation. And must be reflected in the customer's module/pack design.

Spec. No.	INR21700-48X	Version No.	0.0
-----------	--------------	-------------	-----

**Operating Current Limit**

30sec Discharge Current Limit(A) \*SOC0~100 : 4.2-2.5V

Temp.	SOC										
	0	10	20	30	40	50	60	70	80	90	100
-30	0.0	0.0	0.0	0.5	0.5	0.5	0.8	1.0	1.0	1.0	1.0
-20	0.0	0.3	1.0	1.0	1.0	2.0	2.0	2.0	2.0	2.0	2.0
-10	0.0	0.5	2.0	3.0	3.0	4.0	4.0	4.0	5.0	5.0	5.0
0	0.0	1.0	3.0	4.0	5.0	5.0	6.0	6.0	6.0	7.0	7.0
10	0.0	2.0	5.0	6.0	7.0	7.0	8.0	9.0	9.0	9.0	9.0
25	0.0	3.0	7.0	9.0	10.0	10.0	11.0	12.0	12.0	13.0	13.0
45	0.0	3.0	7.0	9.0	10.0	10.0	11.0	12.0	12.0	13.0	13.0
50	0.0	2.0	4.0	6.0	6.0	7.0	7.0	8.0	8.0	8.0	8.0
60	0.0	1.0	2.0	2.0	3.0	3.0	3.0	3.0	3.0	4.0	4.0

10sec Charge Current Limit(A)

Temp.	SOC										
	0	10	20	30	40	50	60	70	80	90	100
-30	0.1	0.1	0.1	0.1	0.1	0.1	0.1	0.1	0.1	0.1	0.0
-20	0.3	0.3	0.3	0.3	0.2	0.2	0.1	0.1	0.1	0.1	0.0
-10	2.7	2.4	2.4	1.5	1.5	1.2	0.9	0.6	0.3	0.1	0.0
0	3.6	3.6	3.6	3.0	2.4	2.4	1.8	1.2	0.6	0.3	0.0
10	5.1	5.1	4.2	4.2	4.2	3.6	3.0	2.1	1.2	0.6	0.0
25	6.3	6.3	6.3	6.3	6.0	5.1	3.9	3.0	1.8	1.2	0.0
45	6.3	6.3	6.3	6.3	6.0	5.1	3.9	3.0	1.8	1.2	0.0
50	4.2	4.2	4.2	4.2	4.0	3.4	2.6	2.0	1.2	0.8	0.0
60	3.1	3.1	3.1	3.1	3.0	2.5	1.9	1.5	0.9	0.6	0.0

Continuous(<120s) Discharge Current Limit(A)

Temp.	SOC										
	0	10	20	30	40	50	60	70	80	90	100
-30	0.0	0.0	0.0	0.2	0.2	0.2	0.2	0.5	1.0	1.0	1.0
-20	0.0	0.2	0.5	0.5	0.5	0.5	1.5	1.5	1.5	1.5	1.5
-10	0.0	0.3	1.5	2.5	2.5	3.5	3.5	3.5	3.5	3.5	3.5
0	0.0	1.0	2.5	3.5	4.5	4.5	5.0	5.0	5.0	6.0	6.0
10	0.0	1.8	4.0	5.0	6.0	6.0	7.0	8.0	8.0	8.0	8.0
15	0.0	1.8	4.0	5.0	6.0	6.0	7.0	8.0	8.0	8.0	8.0
25	0.0	2.0	5.0	7.0	8.0	8.0	10.0	10.0	10.0	12.0	12.0
45	0.0	1.3	3.3	4.5	5.0	5.0	6.5	6.5	6.5	8.0	8.0
50	0.0	1.0	3.0	3.0	3.0	3.0	3.0	3.0	3.0	3.0	3.0
60	0.0	0.7	1.0	1.0	2.0	2.0	2.0	2.0	2.0	2.0	2.0

Continuous Charge Current Limit(A)

Temp.	SOC										
	0	10	20	30	40	50	60	70	80	90	100
-30	0.0	0.0	0.0	0.0	0.0	0.0	0.0	0.0	0.0	0.0	0.0
-20	0.0	0.0	0.0	0.0	0.0	0.0	0.0	0.0	0.0	0.0	0.0
-10	0.0	0.0	0.0	0.0	0.0	0.0	0.0	0.0	0.0	0.0	0.0
0	0.9	0.9	0.9	0.9	0.9	0.7	0.7	0.5	0.5	0.3	0.0
10	1.2	1.2	1.2	1.2	1.2	1.2	1.2	1.2	0.9	0.6	0.0
15	2.4	2.4	2.4	2.4	2.4	2.4	2.4	1.8	1.2	0.7	0.0
25	4.8	4.8	4.8	4.8	4.8	4.2	3.3	2.7	1.5	0.9	0.0
45	4.8	4.8	4.8	4.8	4.8	4.2	3.3	2.7	1.5	0.9	0.0
50	1.4	1.4	1.4	1.4	1.4	1.4	1.4	1.4	1.0	0.6	0.0
60	0.0	0.0	0.0	0.0	0.0	0.0	0.0	0.0	0.0	0.0	0.0

- This above table has been prepared to help minimize field cycle degradation, therefore must be reflected in the customer's module/pack design.

Spec. No.	INR21700-48X	Version No.	0.0
-----------	--------------	-------------	-----

## 12. Cell Sorting Guideline

- Cell Stock Condition : Temp 25±3℃, Humidity less than 60%
- FIFO(First in, first out)
- Batch Mixing : Within 1Month (30days) after receiving
- Do not mix use mass production cells with sample cells
- Do not mix use cells from different manufacturing site
- Cell should be checked before being used (appearance, dv and IR etc)

Model	Shipping SOC	Cell OCV	Cell IR
<input checked="" type="checkbox"/> INR21700-48X	30%	TBD	Same as spec.

$$\textcircled{1} \quad \overline{dV} = \frac{\sum_{\text{Cell } i}^{\text{Sample}} (OCV1 - OCV2)}{\text{Sample Quantity}}$$

- OCV1 = OCV information of 2D Barcode (Measured OCV @ Samsung)
- OCV2 = Present OCV by measuring

- ② Each cell's dV screen range :  $\overline{dV} - 4\text{mV} \leq (OCV1 - OCV2) \leq \overline{dV} + 2\text{mV}$   
 ※ Standard value (-4/+2mV) will be able to change depending on shipping period.

Spec. No.	INR21700-48X	Version No.	0.0
-----------	--------------	-------------	-----

### 13. Pack Safety Design Guideline

#### 13-1. Pack Safety Design Guideline (For electrical design)

Item	Caution	Warning	Control	Protection	Remark
Cell Over Voltage	4.200V	4.230V	4.250V	4.250V	Warning & Protection
Cell Under Voltage	3.40V	3.00V	2.50V	2.50V	Warning & Protection
Warring SOC %	SOC 40%	SOC 30%	SOC 20%	SOC 0%	Power Control
Charging Over Temperature	45°C	50°C	55°C	55°C	Warning & Protection
Charging Under Temperature	10°C	5°C	0°C	0°C	Power Control
Discharging Over Temperature	50°C	55°C	60°C	65°C	Power Control
Discharging Under Temperature	0°C	-15°C	-30°C	-35°C	Power Control
Charging Over Current	0.8C	0.9C	1.0C	1.0C	Protection
Discharging Over Current	4.0C	5.0C	6.0C	6.0C	Protection
Charging Imbalance Voltage	100mV	200mV	300mV	300mV	Warning & Protection
Discharging Imbalance Voltage	150mV	3000mV	500mV	500mV	Warning & Protection
Charging Imbalance Temp	5°C	10°C	15°C	15°C	Warning & Protection
Discharging Imbalance Temp	10°C	15°C	20°C	20°C	Warning & Protection
Communication Error			○	○	Protection
Thermal Runaway			○	○	Protection

Spec. No.	INR21700-48X	Version No.	0.0
-----------	--------------	-------------	-----

### 13-2. Pack Safety Design Guideline (For mechanical design)

Sector	Item	Unit	Specification
Module Design	☒ Thermal Runaway Design	Module Design Checking	1. The purpose of gap between each cell in battery pack is; 1) to minimize risk of fire of adjacent battery cells 2) to prevent degradation of cell or CID open due to exposure on high temperature through facilitating heat emission → <b>At least 2.0mm gap between each cell must be maintained.</b> → <b>Each cell cap-up area shall be exposed over 2/3 of the area for smooth ventilation.</b> 2. Cell core case shall not be flamed. → <b>Cell core case must be non-flammable level V0 (or above V0).</b>
	☒ Current Distribution Design	Module Design Checking	Basically, battery pack for xEV is composed of significant amount of cylindrical battery cells by serial-parallel. With this significant serial-parallel structure, level of cycle life, heat, voltage imbalance at charging or discharging, and safety level will be effected by current distribution design of the battery pack. → <b>The current distribution design of pack must enable even distribution of current on each cell when charging/discharging.</b>
	☒ Heat Generation (Ni Tab & Cell Body)	1.0C to 2.0C Discharging Test	Abnormal heat source from the welding material can damage the battery (thermal damage). This phenomenon can cause safety or charging/discharging efficiency issues. → <b>The temperature between the welding material and battery cell body must be under 10degC at maximum continuous discharge.</b>
	☒ Non Soldering Design	Welding Design Checking	If battery cell is soldered, this can cause leakage of cell or unpredictable defect due to thermal damage. → <b>Soldering is PROHIBITED. Samsung SDI will NOT be liable for any defects caused by customer's misuse of the battery cells (including soldering).</b>
Pack Design	☒ Thermal Imbalance Check	Simulation / Discharging Test	Thermal management for Li-ion battery pack of xEV that is composed of significant amount of cylindrical Li-ion battery cell is very important. If the customer fails to equalize temperature in the battery pack, this can cause abnormal degradation of cycle life, imbalance, or inefficiency of charging/discharging. → <b>The temperature difference between the center of the battery pack and each side of the pack must be below 5°C when charging, and under 10°C when discharging, which must be facilitated through proper thermal management.</b> ※ If needed, Samsung SDI can request and check thermal distribution record of xEV pack and voltage imbalance data during pack charging/discharging from the customers.
	☒ BOL Charging Imbalance Check	Rated Charging Test	
	☒ BOL Discharging Imbalance Check	1.0C Discharging Test	

- Samsung SDI may, at any time, conduct module or pack analyses at the customer's site to check the customer's compliance with the above specifications. The customer must provide all necessary assistance to Samsung SDI.
- If the parties are unable to resolve issues found during such site inspection, Samsung SDI may refuse to supply further products to the customer.

**- Samsung SDI may, at any time, conduct module or pack analyses at the customer's site to check the customer's compliance with the above specifications. The customer must provide all necessary assistance to Samsung SDI.**

**- If the parties are unable to resolve issues found during such site inspection, Samsung SDI may refuse to supply further products to the customer.**

Spec. No.	INR21700-48X	Version No.	0.0
-----------	--------------	-------------	-----

## 14. Operating Charging Guide

Temperature (°C)	< 0	0~5	5~10	10~20	20~30	30~40	40~50	> 50
Charging Condition		0.2C 4.100V	0.3C 4.100V	0.5C 4.100V	0.7C 4.100V	1.0C 4.100V	0.33C 4.050V	Not Permitted
Heating	Not Permitted	Need	X	X	X	X	X	
Cooling		X	X	X	X	Need	Need	

### ※ Notice

- **Regeneration Charging < SOC 90%, Less than 10sec**
- **[Heating guide] Heating Start Temperature: 0°C / Heating End Temperature: 5°C**
- **[Cooling guide] Need to maintain temperature 32±2°C**

## 15. Compliance

- . Customer shall comply with cell's warranty conditions and guidelines in the specification sheet, and customer shall immediately notify Samsung SDI if customer reasonably believes that it cannot comply with the aforementioned conditions and guidelines.

## 16. Others

### 16.1 Storage for a long time

If Cell is kept for a long time (3months or more), It is strongly recommended that Cell is preserved at dry and low-temperature.

### 16.2 Other

Any matters that specifications does not have, should be conferred with between the both parties.

## Proper Use and Handling of Lithium Ion Cells

See before using lithium-ion cell

This document has been prepared to describe the appropriate cautions and prohibitions, which the customer should take or employ when the customer uses and handles the lithium ion cell to be manufactured and supplied by Samsung SDI in order to obtain optimum performance and safety.

## 1. Charging

Spec. No.	INR21700-48X	Version No.	0.0
-----------	--------------	-------------	-----

### 1.1 Charging current

Charging current should be less than maximum charge current specified in the product specification.

### 1.2 Charging voltage

Charging should be done by voltage less than that specified in the product specification.

### 1.3 Charging time

Continuous charging under specified voltage does not cause any loss of performance characteristics. However, the charge timer is recommended to be installed from a safety consideration, which shuts off further charging at time specified in the product specification.

### 1.4 Charging temperature

Cell should be charged within a range of specified temperatures in the specification.

### 1.5 Reverse charging

Cell should be connected, confirming that its poles are correctly aligned. Inverse charging should be strictly prohibited. If Cell is connected improperly, it may be damaged.

## 2. Discharging

### 2.1 Discharging

Cell shall be discharged continuously at less than maximum discharge current specified in the product specification. In case of the higher discharge current should be set, it shall be discussed together with SDI.

### 2.2 Discharging temperature

2.2.1 Cell should be discharged within a range of temperatures specified in the product specification.

2.2.2 Otherwise, it may cause loss of characteristics.

Spec. No.	INR21700-48X	Version No.	0.0
-----------	--------------	-------------	-----

### 2.3 Over-discharging

- 2.3.1 The system should be equipped with a device to prevent further discharging exceeding discharging cut-off voltage specified in the product specification.
- 2.3.2 Over-discharging may cause loss of performance, characteristics of battery function.
- 2.3.3 Over-discharging may occur by self-discharge if the battery is left for a very long time without any use.
- 2.3.4 The charger should be equipped with a device to detect Cell voltage and to determine recharging procedures.

## 3. Storage

### 3.1 Storage conditions

- 3.1.1 Cell should be stored within a range of temperatures specified as below\*1.

\*1 Store the battery at 0 ~ 23°C, low humidity (below 60%), no dust and no corrosive gas atmosphere

- 3.1.2 Otherwise, it may cause loss of performance characteristics, leakage and/or rust etc.

### 3.2 Long-term storage

- 3.2.1 Cell should be used within a short period after charging because long-term storage may cause loss of capacity by self-discharging.
- 3.2.2 If long-term (but not longer than Warranty Period as set forth in Section 10 (Warranty)) storage is necessary, Cell shall be stored at shipping voltage, because storage with higher voltage may cause more loss of performance characteristics.

- 3.3 Storage period : Samsung SDI shall not be liable for any defects of cell after a period of 12 months from the date of shipping even if Cell is stored in accordance with Sections 3.1 and 3.2 above.

## 4. Cycle life

### 4.1 Cycle life performance

- 4.1.1 Cell can be charged/discharged repeatedly up to times specified in the produce specification with a certain level of capacity also specified in the product specification.
- 4.1.2 Cycle life may be determined by conditions of charging, discharging, operating temperature and/or storage.

## 5. Battery Pack Assembly

### 5.1 Prohibition of usage of damaged Cell

- 5.1.1 Cell should be inspected visually before battery assembly.

Spec. No.	INR21700-48X	Version No.	0.0
-----------	--------------	-------------	-----

5.1.2 Cell should not be used if sleeve-damage, can-distortion and/or electrolyte-smell is detected.

## 5.2 Terminals handling

5.2.1 Excessive force on the negative terminal should be avoided when external strip terminal is welded.

## 5.3 Transportation

5.3.1 If Cell is necessary to be transported to such as the battery manufacturer, careful precautions should be taken to avoid damage of Cell.

## 6. Others

### 6.1 Disassembly

6.1.1 Cell should not be dismantled from the battery pack.

6.1.2 Internal short-circuit caused by disassembly may lead to heat generation and/or venting.

6.1.3 When the electrolyte is coming in contact with the skin or eyes, wash immediately with fresh water and seek medical advice.

### 6.2 Short-circuiting

6.2.1 Short-circuit results in very high current which leads to heat generation.

6.2.2 An appropriate circuitry should be employed to protect accidental short-circuiting.

### 6.3 Incineration

6.3.1 Incinerating and disposing of Cell in fire are strictly prohibited, because it may cause rupture and explosion.

### 6.4 Immersion

6.4.1 Soaking Cell in water is strictly prohibited, because it may cause corrosion and leakage of components to be damaged to functions.

### 6.5 Mixing use

6.5.1 Different types of Cell, or same types but different Cell manufacturer's shall not be used, which may lead to Cell imbalance, Cell rupture or damage to system due to the different characteristics of Cell.

6.5.2 Do not mix use Cells from different batches/ranks even they are the same Cell types from the same manufacturer.

### 6.6 Battery disposal

6.6.1 Although Cell contains no environmentally hazardous component, such as lead or cadmium. the battery should be disposed according to the local regulations when it is disposed.

6.6.2 Cell should be disposed with a discharged state to avoid heat generation by an inadvertent short-circuit.



Spec. No.	INR21700-48X	Version No.	0.0
-----------	--------------	-------------	-----

## 6.7 Caution

- 6.7.1 The Battery used in this device may present a risk of fire or chemical burn if mistreated.
- 6.7.2 Do not disassemble, expose to heat above 100°C or incinerate it.
- 6.7.3 Replace battery with Samsung SDI battery only.
- 6.7.4 Use of another battery may present a risk of fire or explosion.
- 6.7.5 Dispose of used battery promptly.
- 6.7.6 Keep away from children.
- 6.7.7 Do not disassemble and do not dispose of in fire.

Spec. No.	INR21700-48X	Version No.	0.0
-----------	--------------	-------------	-----

## Handling precaution and prohibitions of lithium rechargeable Cells and batteries

Inaccurate handling of lithium ion and lithium ion batteries rechargeable battery may cause leakage, heat, smoke, an explosion, or fire.

This could cause deterioration of performance or failure. Please be sure to follow instructions carefully.

### 1. Safety precaution and prohibitions

To assure product safety, describe the following precautions in the instruction manual of the application.

### 2. Danger

#### 2.1 Electrical misuseage

2.1.1 Use dedicated charger.

2.1.2 Use or charge the battery only in the dedicated application.

2.1.3 Don't charge the battery by an electric outlet directly or a cigarette lighter charger.

2.1.4 Don't charge the battery reversely.

#### 2.2 Environmental misuseage

2.2.1 Don't leave the battery near the fire or a heated source.

2.2.2 Don't throw the battery into the fire.

2.2.3 Don't leave, charge or use the battery in a car or similar place where inside of temperature may be over 60°C.

2.2.4 Don't immerse, throw, wet the battery in water / seawater.

#### 2.3 Others

2.3.1 Don't fold the battery cased with laminated film such as pouch and Polymer.

2.3.2 Don't store the battery in a pocket or a bag together with metallic objects such as keys, necklaces, hairpins, coins, or screws.

2.3.3 Don't short circuit (+) and (-) terminals with metallic object intentionally.

2.3.4 Don't pierce the battery with a sharp object such as a needle, screw drivers.

2.3.5 Don't heat partial area of the battery with heated objects such as soldering iron.

2.3.6 Don't hit with heavy objects such as a hammer, weight.

2.3.7 Don't step on the battery and throw or drop the battery on the hard floor to avoid mechanical hock.

2.3.8 Don't disassemble the battery or modify the battery design including electric circuit.

2.3.9 Don't solder on the battery directly.

2.3.10 Don't use seriously scarred or deformed battery.

2.3.11 Don't put the battery into a microwave oven, dryer ,or high-pressure container.

2.3.12 Don't use or assemble the battery with other makers' batteries, different types and/or models of batteries such as dry batteries, nickel-metal hydride batteries, or nickel-cadmium batteries.

2.3.13 Don't use or assemble old and new batteries together.

Spec. No.	INR21700-48X	Version No.	0.0
-----------	--------------	-------------	-----

### 3. Warning

- 3.1 Stop using the battery if the battery becomes abnormally hot, odor, discoloration, deformation, or abnormal conditions is detected during use, charge, or storage.
- 3.2 Keep away from fire immediately when leakage or foul odors are detected. If liquid leaks onto your skin or clothes, wash well with fresh water immediately.
- 3.3 If liquid leaking from the battery gets into your eyes, don't rub your eyes and wash them with clean water and go to see a doctor immediately.
- 3.4 If the terminals of the battery become dirty, wipe with a dry cloth before using the battery.
- 3.5 Cover terminals with proper insulating tape before disposal.

### 4. Caution

- 4.1 Electrical misuseage
  - Battery must be charge with constant current-constant voltage (CC/CV).
- 4.2 Others
  - 4.2.1 Keep the battery away from babies and children to avoid any accidents such as swallow.
  - 4.2.2 If younger children use the battery, their guardians should explain the proper handling method and precaution before using.
  - 4.2.3 Before using the battery, be sure to read the user's manual and precaution of its handling.
  - 4.2.4 Before using charger, be sure to read the user's manual of the charger.
  - 4.2.5 Before installing and removing the battery from application, be sure to read user's manual of the application.
  - 4.2.6 Replace the battery when using time of battery becomes much shorter than usual.
  - 4.2.7 Cover terminals with insulating tape before proper disposal.
  - 4.2.8 If the battery is needed to be stored for an long period, battery should be removed from the application and stored in a place where humidity and temperature are low.
  - 4.2.9 While the battery is charged, used and stored, keep it away from object materials with static electric chargers.

### 5. Safety Handling Procedure for the Transporter

#### 5.1 Quarantine

Packages that are crushed, punctured or torn open to reveal contents should not be transported. Such packages should be isolated until the shipper has been consulted, provided instructions and, if appropriate, arranged to have the product inspected and repacked.

#### 5.2 Spilled Product

In the event that damage to packaging results in the release of Cells or batteries, the spilled products should be promptly collected and segregated and the shipper should be contacted for instructions.

Spec. No.	INR21700-48X	Version No.	0.0
-----------	--------------	-------------	-----

## Samsung SDI emergency contact information

- **Samsung SDI Co., Ltd (Headquarter)**  
 150-20, Gongse-ro, Giheung-gu, Yongin-si, Gyunggi-do, Korea  
 Tel: +82-31-8006-3100, Fax : +82-31-210-7887
- **Samsung SDI Co., Ltd (Cheonan Factory, Production)**  
 467, Beonyeong-ro, Seobuk-gu, Cheonan-si, Chungcheongnam-Do, Korea  
 Tel: +82-41-560-3114, Fax : +82-41-550-3399
- **Samsung SDI China Co., Ltd (Tianjin Factory, Production)**  
 301726, China Tianjin Developing Zone OF Yi-Xian Park, Wuqing Country, TianJin, China  
 Tel: +86-22-8212-9971(5300),
- **Samsung SDI Energy Malaysia SDN. Bhd. (Malaysia Factory, Production)**  
 Lot 635 & 660, Kawasan Perindustrian, Tuanku Jaafar, 71450  
 Sungai Gadut, Negeri Sembilan Darul Khusus, Malaysia  
 Tel: (+60)6-677-6160, 6153, Fax: (+60)6-677-6164
- **Samsung SDI America, Inc (San Jose, Sales)**  
 3655 North First St. San Jose CA 95134  
 Tel: +1-408-544-4541, Fax: +1-949-260-2221
- **Samsung SDI Europe GmbH (Munich, Sales)**  
 85737, Oskar-Messter-Strasse 29 Ismaning, Germany  
 Tel: +49-89-9292-7799(20), Fax: +49-89-9292-7799(99)
- **Samsung SDI Japan Co., Ltd (Tokyo, Sales)**  
 108-0075, Shinagawa Grand Central Tower 9F, 2-16-4, Konan, Minato-ku, Tokyo, Japan  
 Tel. +81-3-6369-6401, +81-3-6369-6404 Fax. +81-3-6369-6388
- **Samsung SDI Taiwan Branch (Taipei, Sales)**  
 7F-1, No.399, Ruiguang Rd., Neihu Dist., Taipei Taiwan (ROC)  
 Tel +886-2-8178-5900, Fax +886-2-8751-3131
- **Samsung SDI India Branch (New Delhi, Sales)**  
 1st Fl.M-6 Uppal's Plaza, Jasola District Centre, New Delhi 110025, INDIA  
 Tel. +91-11-4316-1224, +91-11-4316-1221 Fax. +91-11-4316-1200