

# Temperature Dependence of Discharge Capacity (US18650VC7)

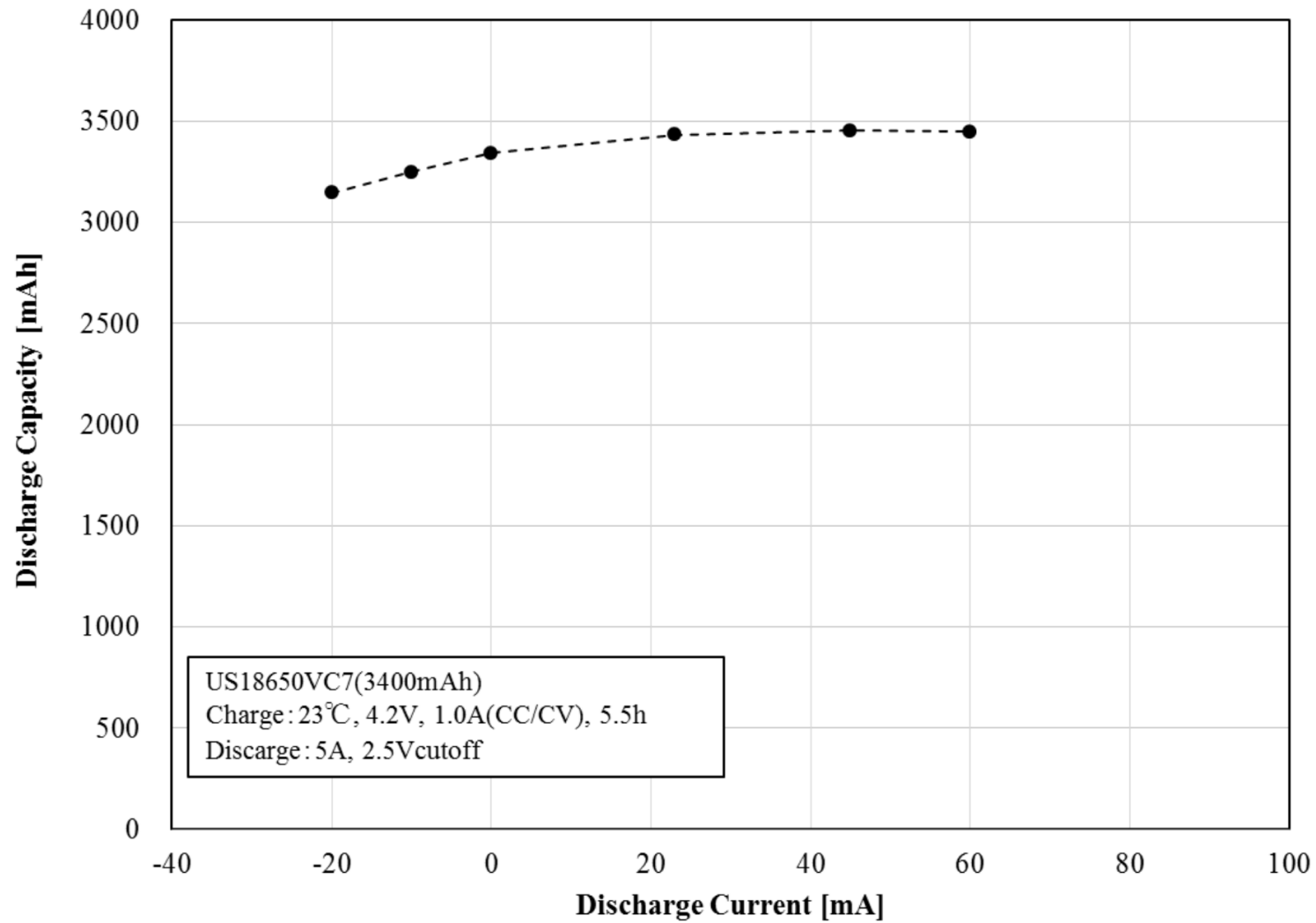

# Temperature Dependence of Discharge Capacity (US18650VC7)

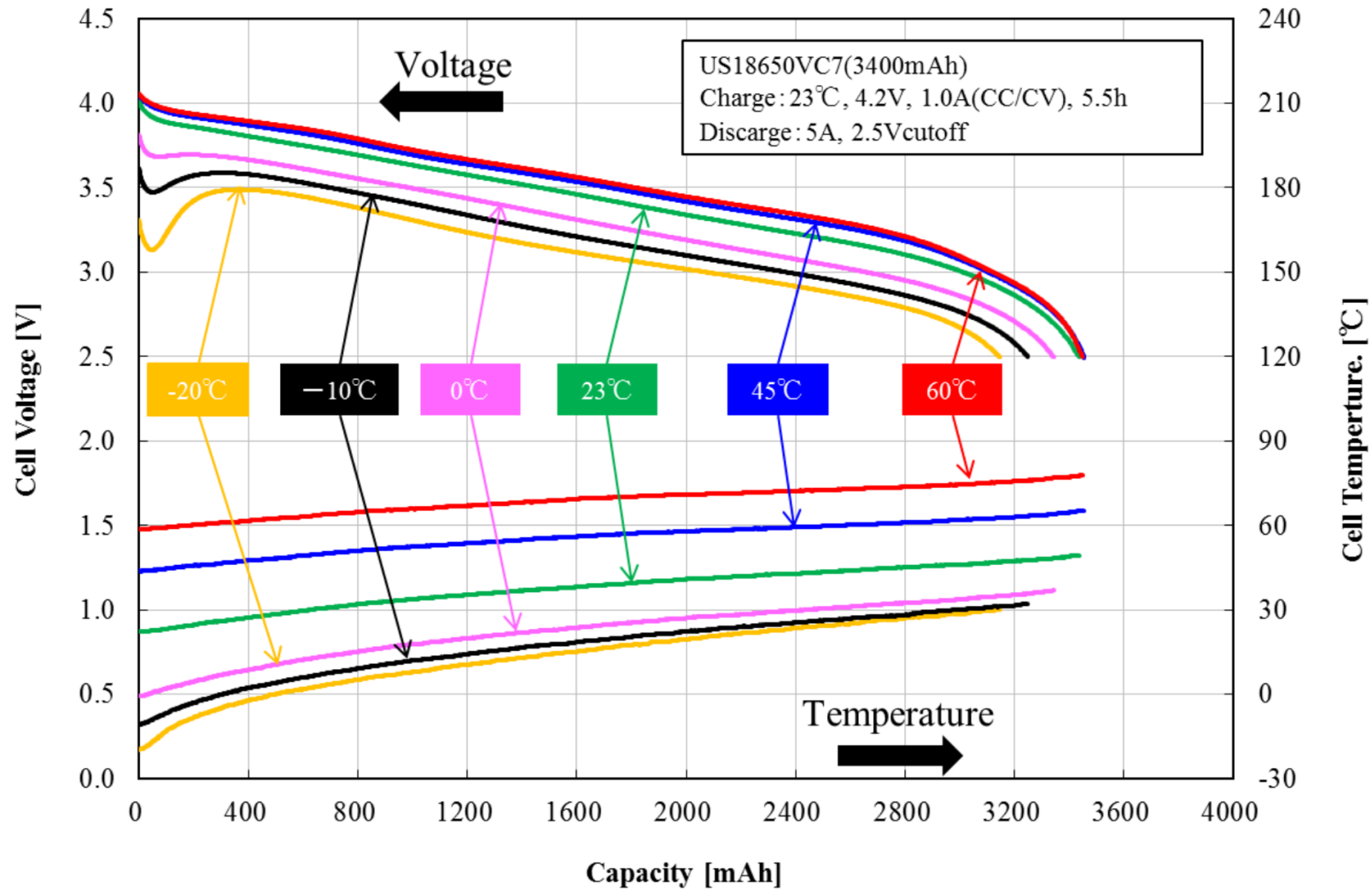

# Discharge Load Characteristics (US18650VC7)

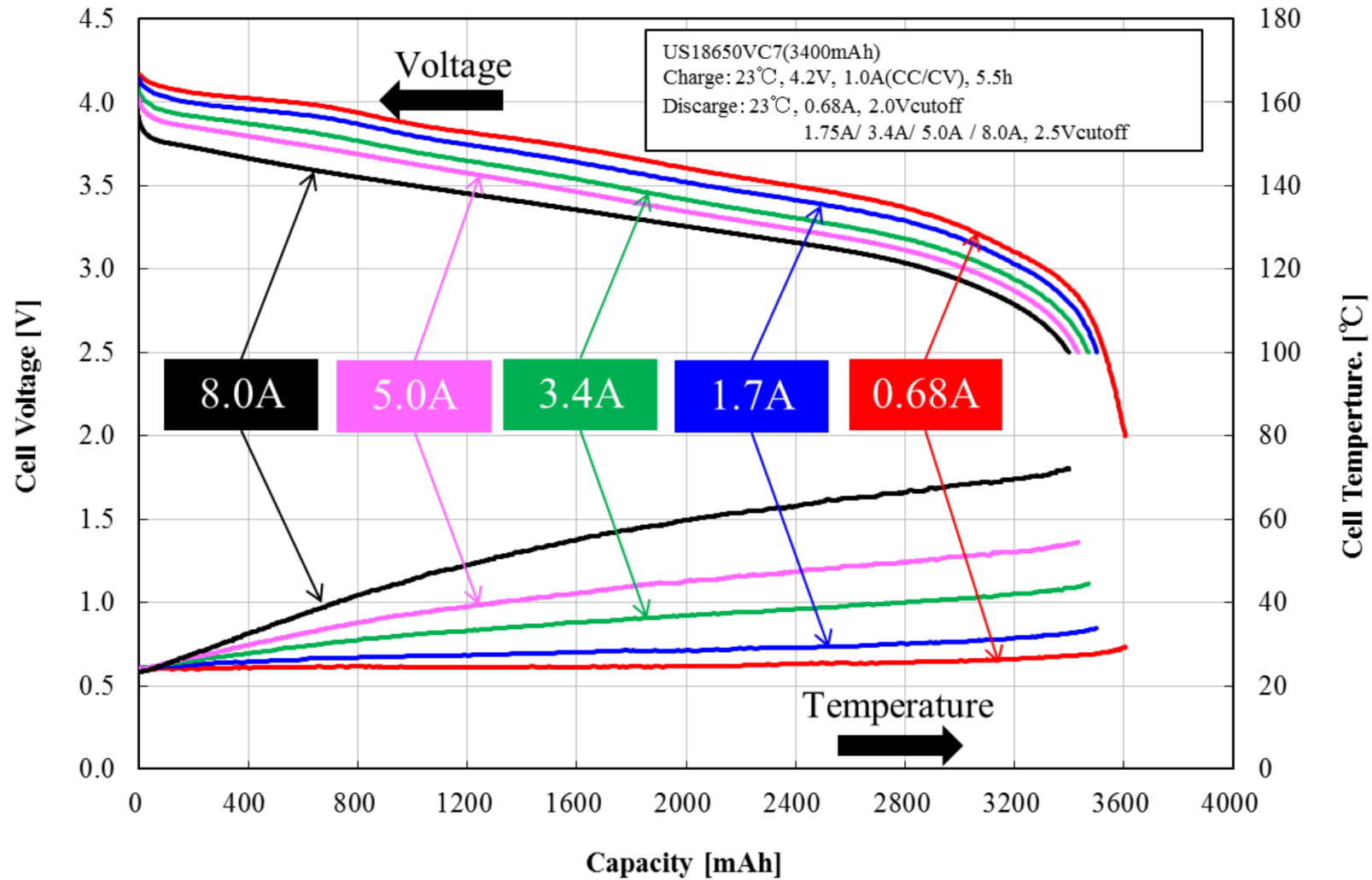

# Charge Characteristics (US18650VC7)

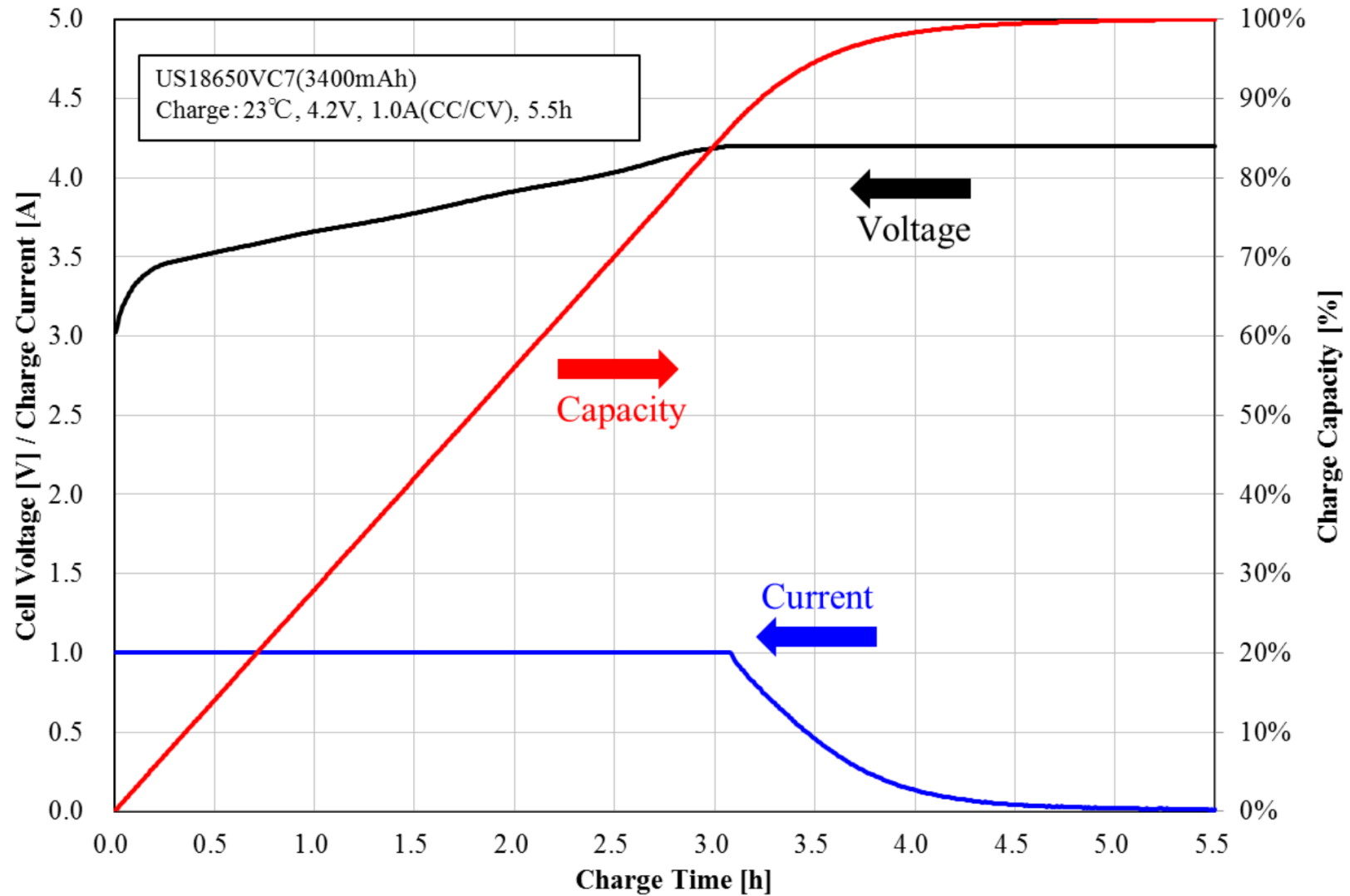

# Dimension with Plastic Tube (US18650VC7)

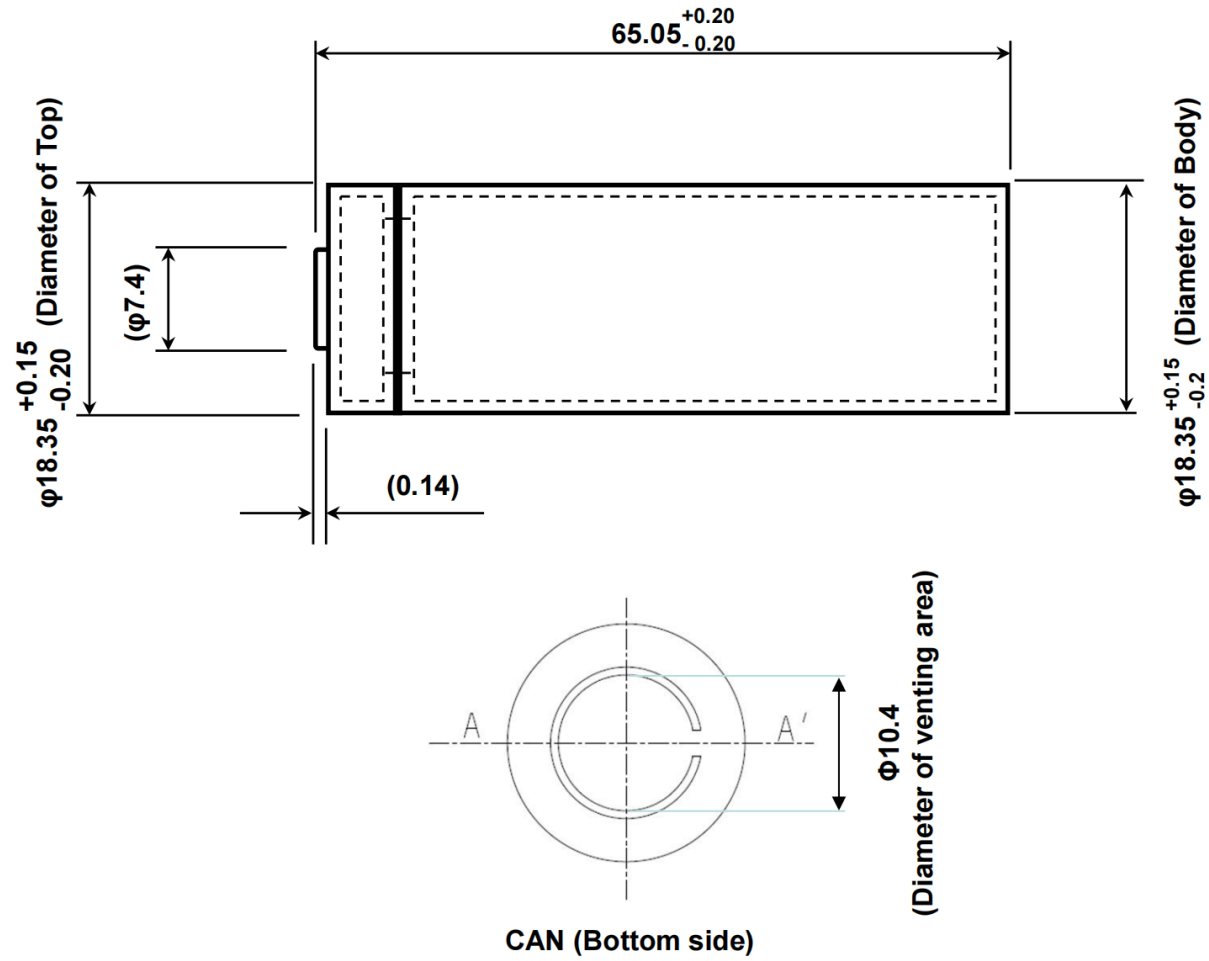

# Cycle Life Performance (US18650VC7)

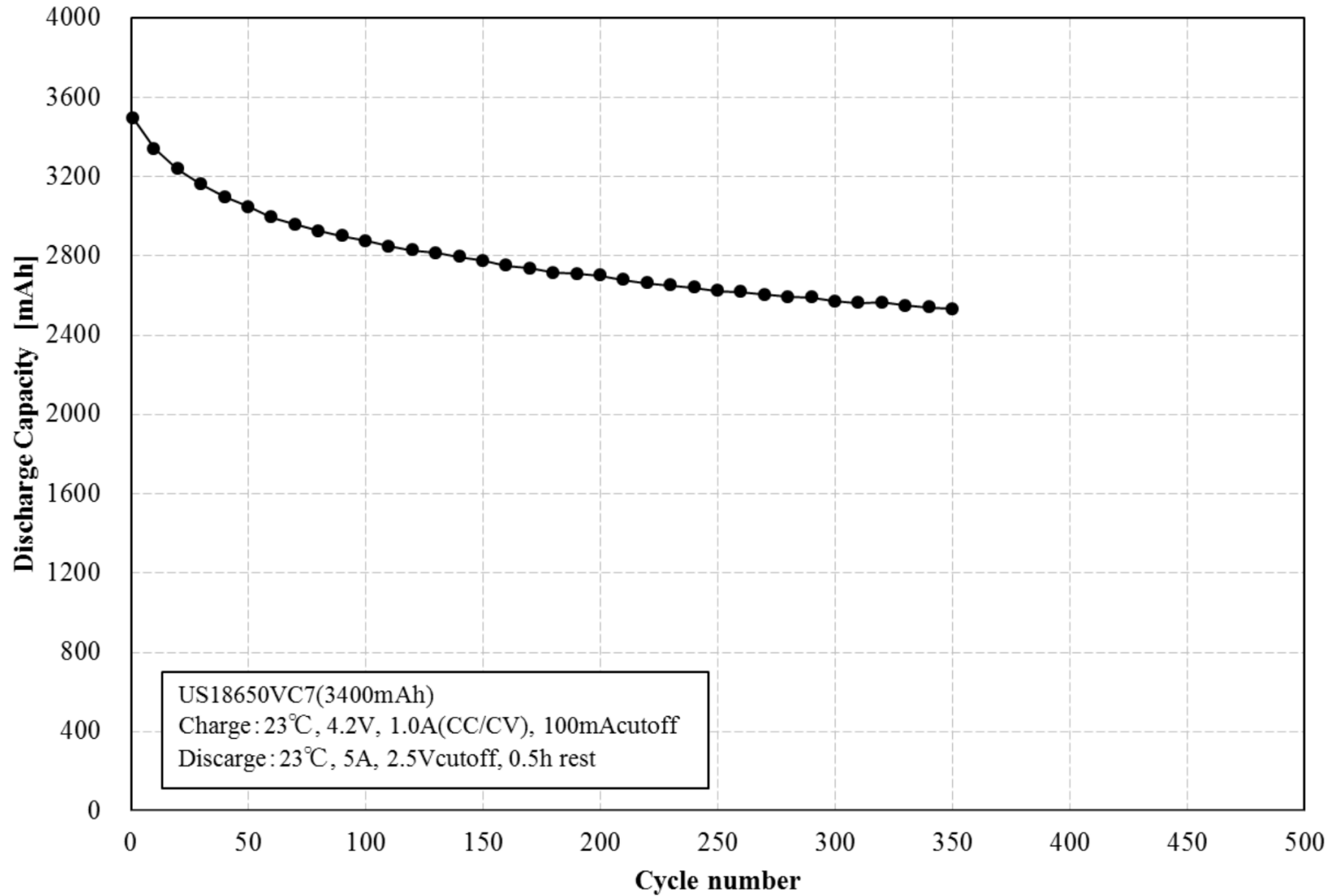

# Discharge Load Characteristics (US18650VC7)

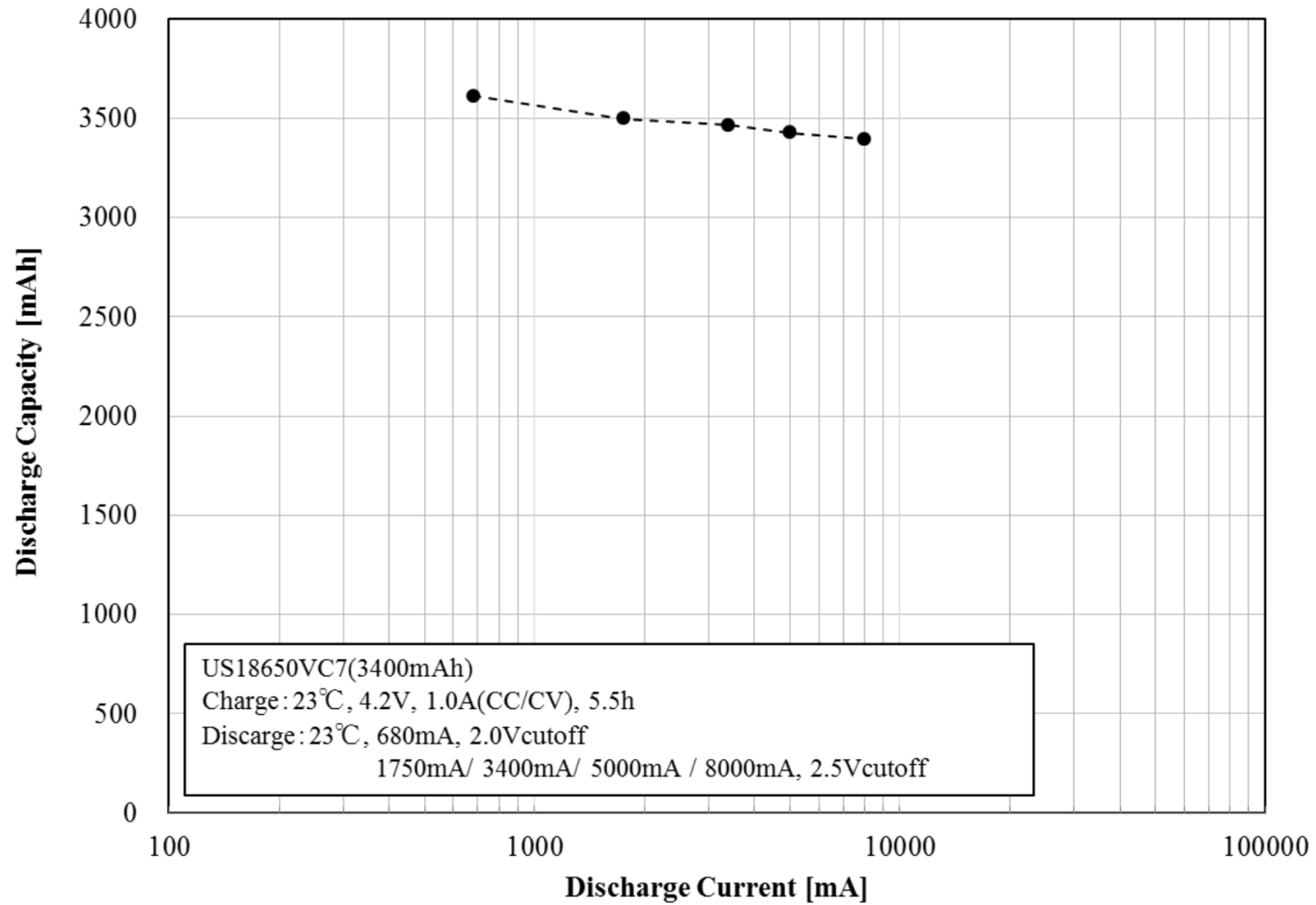

### Protection test: Sony US18650VC7 3400mAh

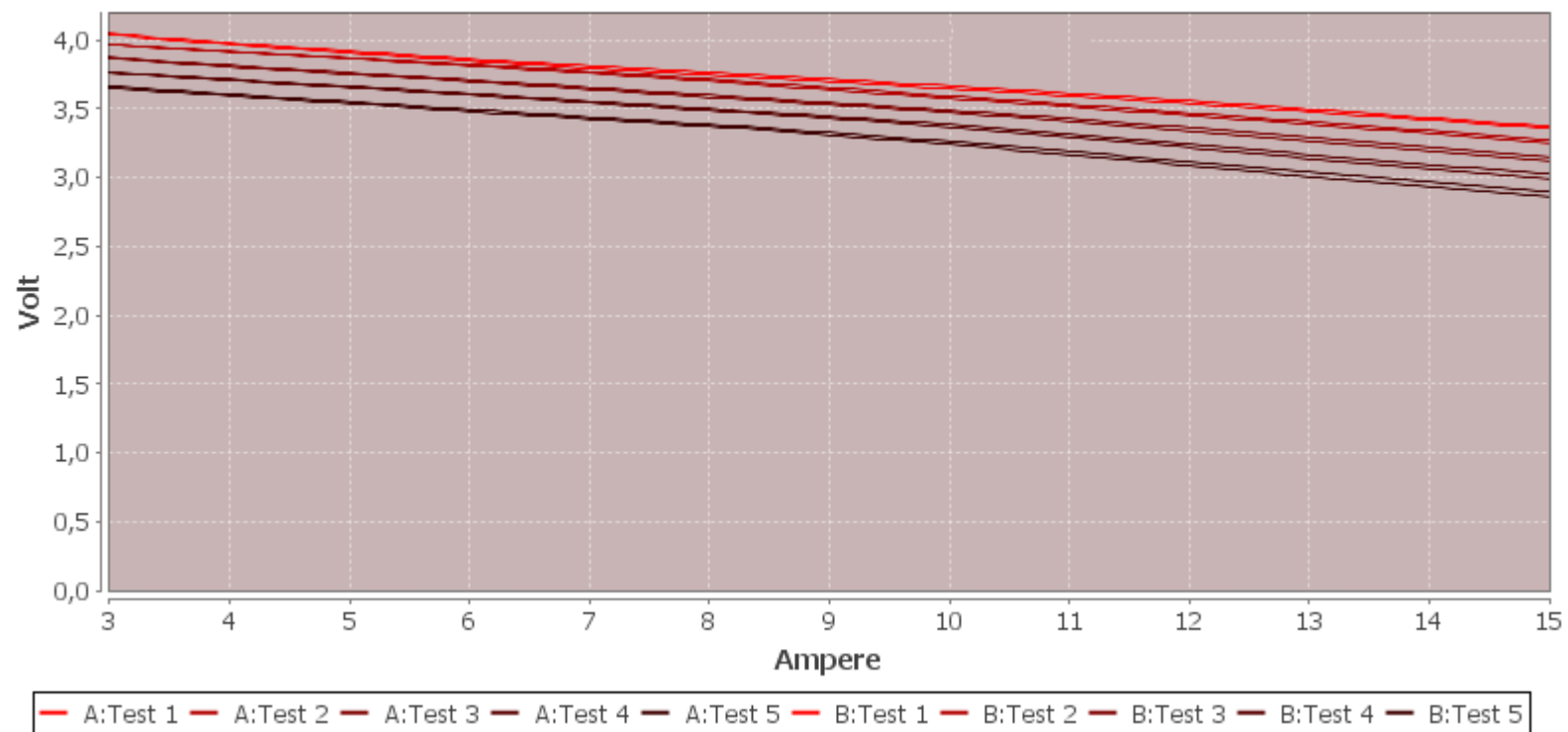



### Discharge, capacity: Sony US18650VC7 3400mAh

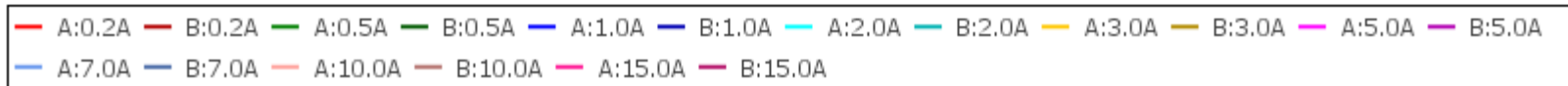
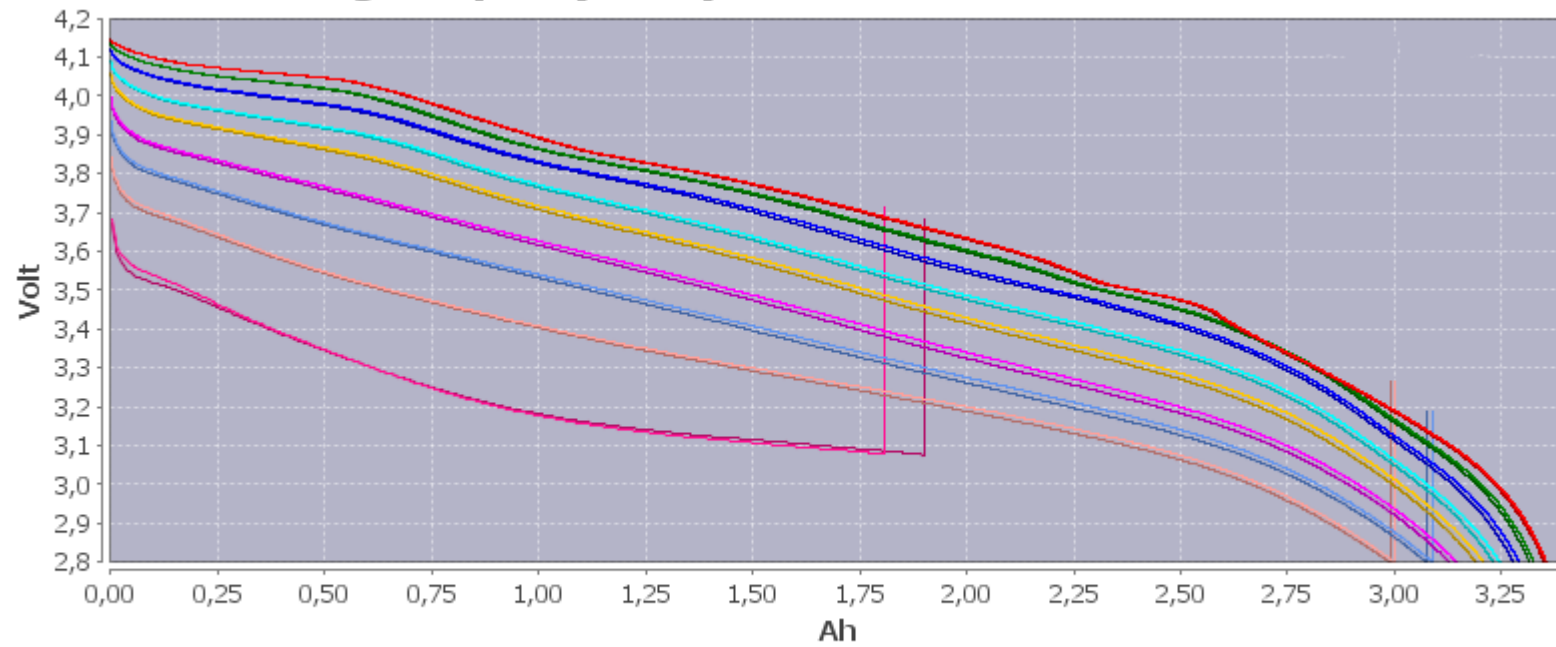

### Discharge, time: Sony US18650VC7 3400mAh

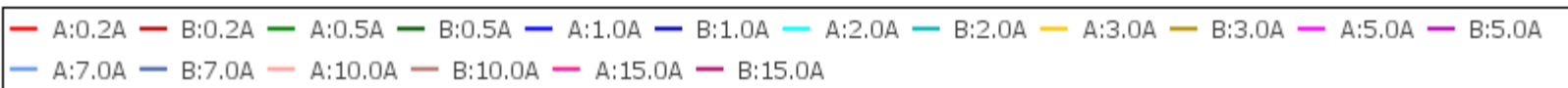
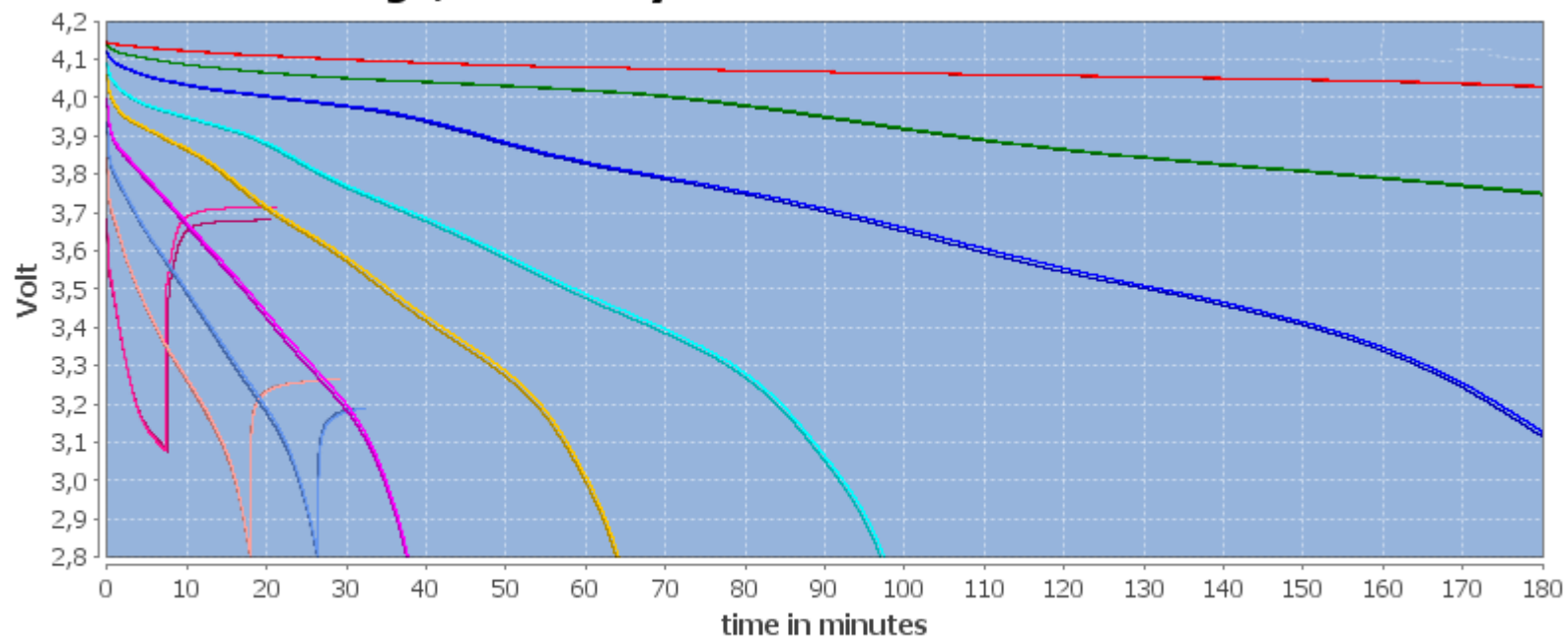

### Discharge, time: Sony US18650VC7 3400mAh

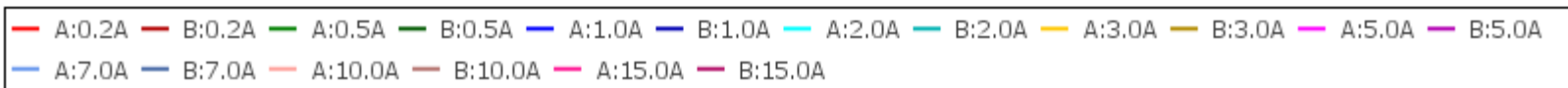
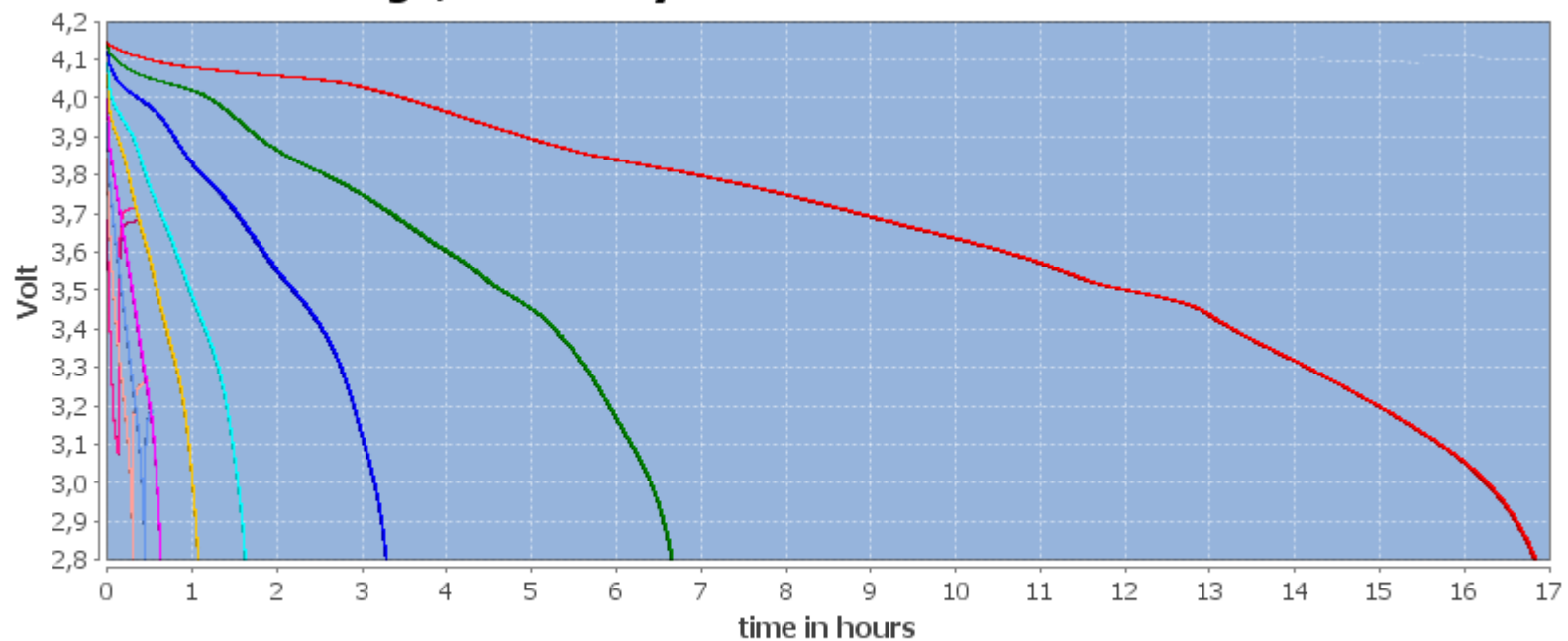

### Charging: Sony US18650VC7 3400mAh

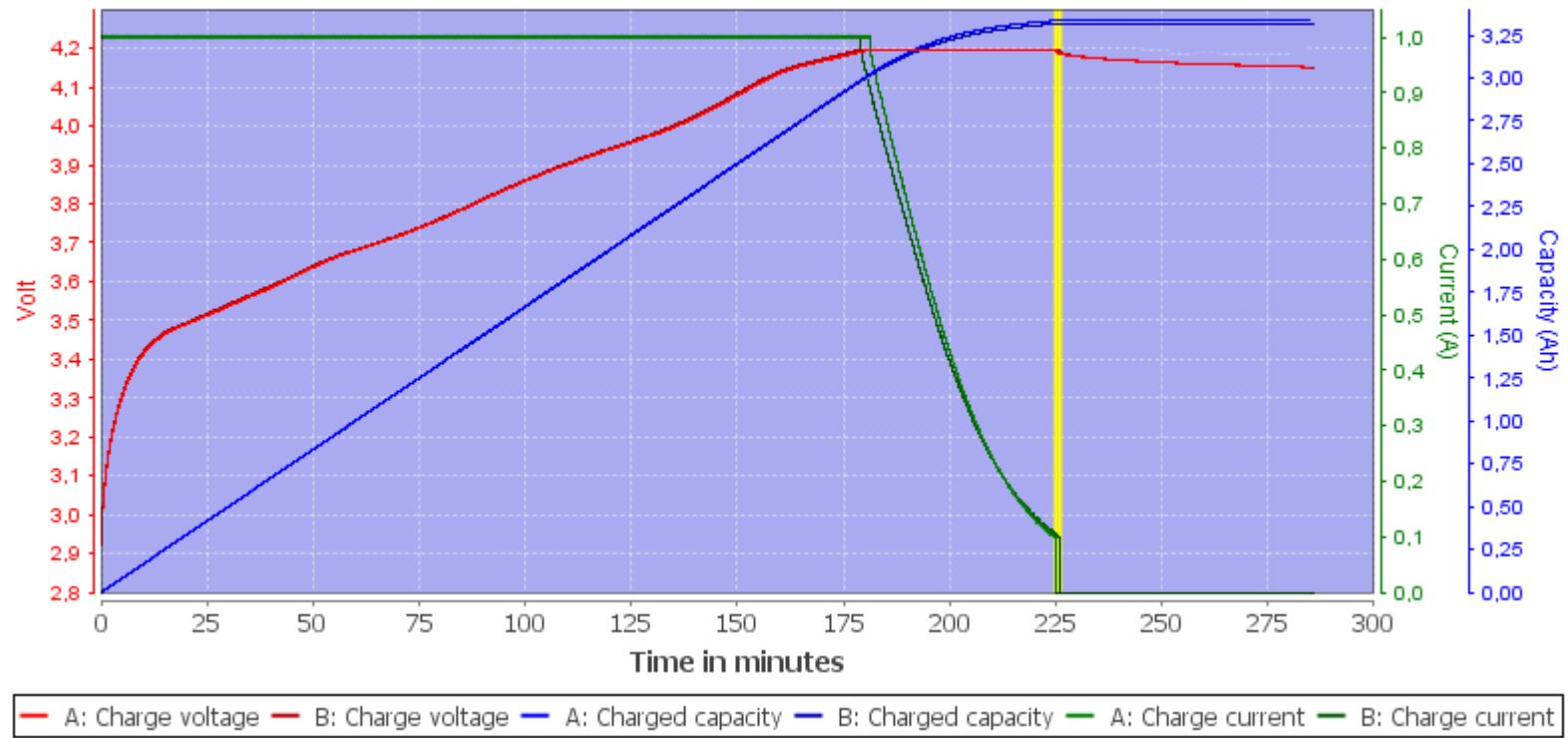

### Discharge, energy: Sony US18650VC7 3400mAh

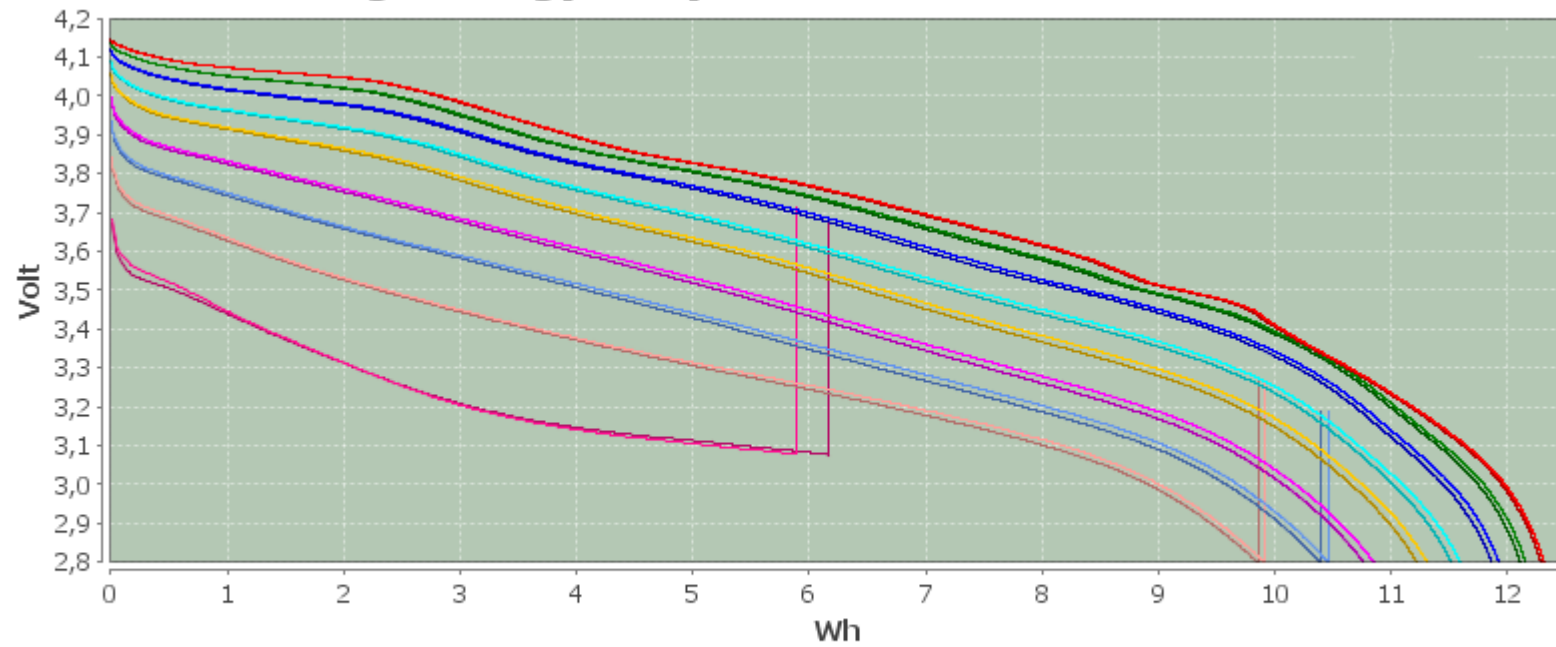

- A:0.2A B:0.2A A:0.5A B:0.5A A:1.0A B:1.0A A:2.0A B:2.0A A:3.0A B:3.0A A:5.0A B:5.0A
- A:7.0A B:7.0A A:10.0A B:10.0A A:15.0A B:15.0A

### Discharge, power: Sony US18650VC7 3400mAh

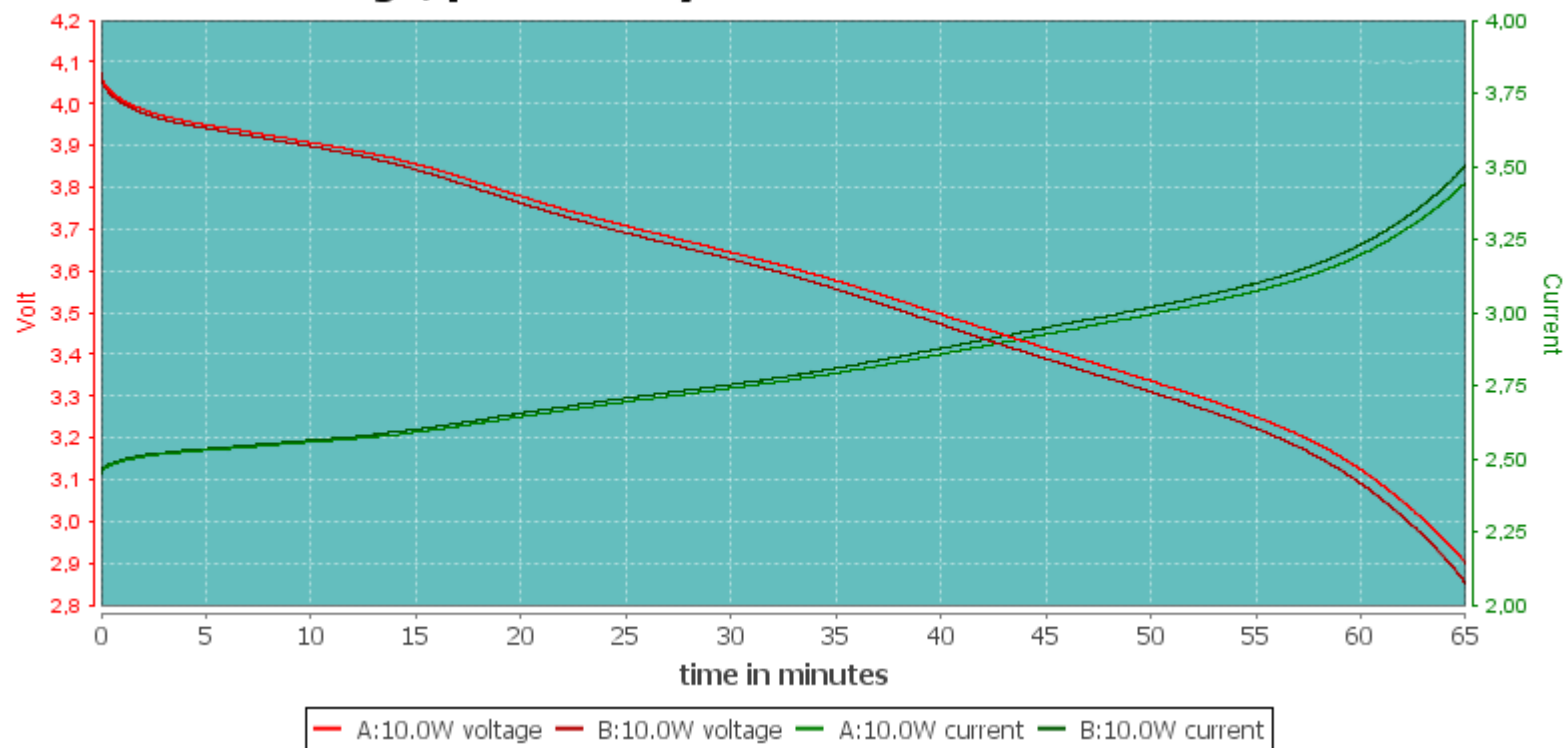

### Discharge 10.0A: Sony US18650VC7 3400mAh

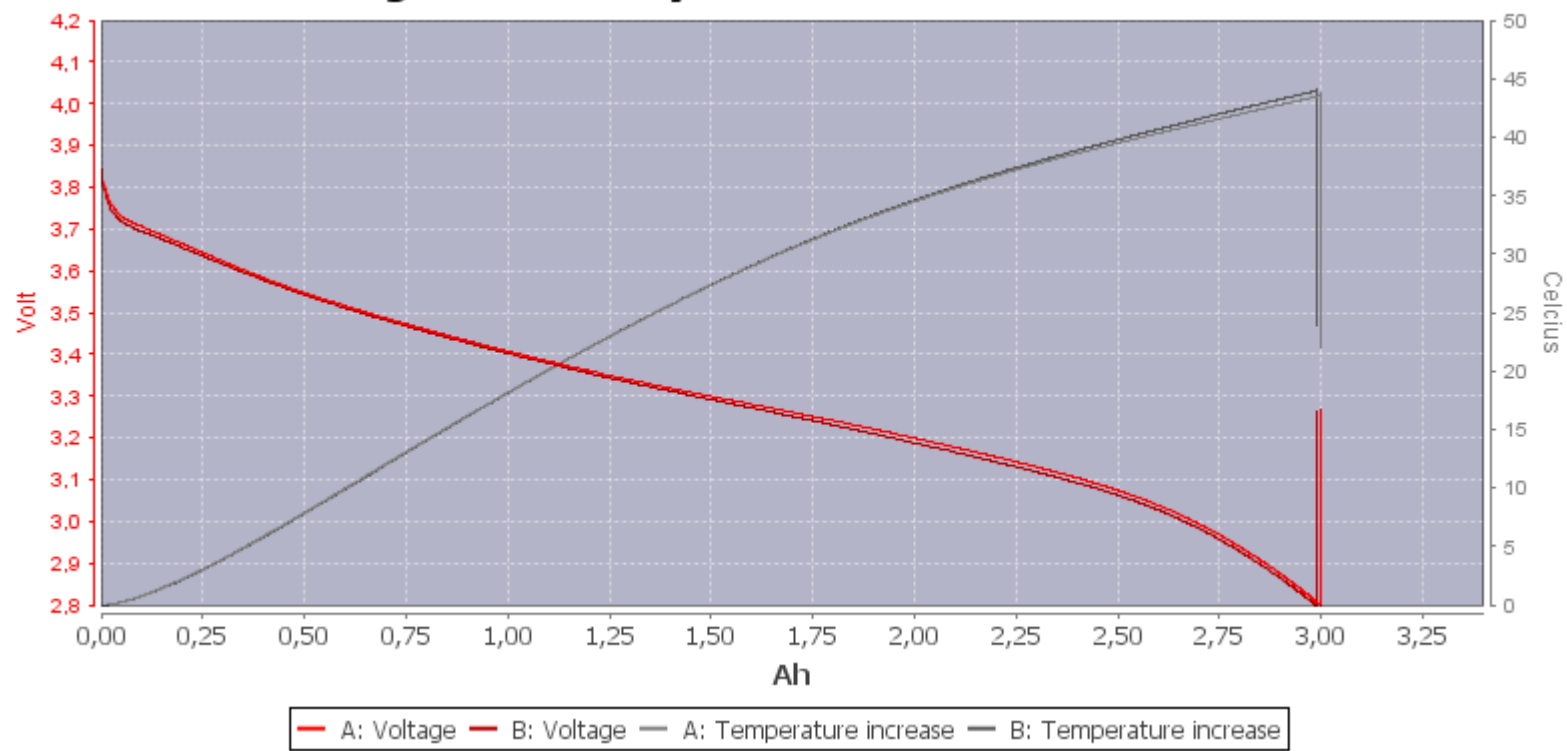

### Discharge 15.0A: Sony US18650VC7 3400mAh

